

STARN A

The Spectroscopy Specialists



Quartz and Glass Cells for:

Spectrophotometers
Fluorometers
Colorimeters
Laser Applications

2012

Catalog and Price List

about Starna Cells, Inc....

The origin of the optical skills available from **Starna**, formed in 1971, can be traced back to the earlier part of the 20th century. Utilizing their optical expertise, the founders of the original company manufactured specialized optics and, during the early 1950s, had already developed the technique necessary for manufacturing the first *fully fused* form of spectrophotometer cells.

As a wholly owned subsidiary of the **Starna** international group of companies, Starna Cells provides many instrument manufacturers with specialized optical components and other private labeled products, including the Starna[®] brand of high quality spectrophotometer cells, accessories and the extensive range of NIST Traceable Liquid Reference Materials.

Starna products are distributed worldwide through the Starna network to instrument manufacturers, distributors and direct to end users. A dedicated technical applications and development team is ready to answer questions.

Cell Construction Specifications

All the cells Starna manufactures, unless specifically designed otherwise, are assembled using a fully fused method. This technique, pioneered and perfected by Starna, ensures that cells are fused into a single homogeneous unit by heat alone, using no intermediate adhesives. The cells achieve maximum physical strength as well as being unaffected by solvents.

All cells are carefully annealed to remove any residual strain left from the fusing process and, with few exceptions, can be used safely with pressure differentials of up to three atmospheres.

General Specifications:

Windows parallel to:	better than 3 minutes of arc
Window flatness to:	less than 4 Newton fringes
Window polish:	60/40 scratch/dig
Window thickness:	1.25mm

Material	Path lengths	Tolerance
Glass	up to 20mm	+/- 0.1mm
Glass	30 to 100mm	+/- 0.2mm
Special Optical Glass	up to 20mm	+/- 0.01mm
Special Optical Glass	30 to 100mm	+/- 0.02mm
Quartz	up to 0.05mm	+/- 0.002mm
Quartz	0.1 to 0.4mm	+/- 0.005mm
Quartz	0.5 to 20mm	+/- 0.01mm
Quartz	40 to 100mm	+/- 0.02mm

The cells can be used with most solvents and acidic solutions. Acids such as HF should be avoided as they will attack the quartz itself while most other acids will not affect the cells. Strongly basic solutions (pH 9.0 and above) will etch the surface of the windows and shorten the useful life of the cells.

Material Specifications

Starna offers five window materials, Optical Glass, Special Optical Glass and Pyrex[®] for the visible range, Spectrosil[®] Quartz for the far UV range and Infrasil[®] Quartz or equivalent for the near infrared. If a material required is not shown in this catalog, please contact us for availability. All materials used to construct the cells are suitable for use in the following wavelength range:

Optical Glass	334 through 2500 nm
Special Optical Glass	320 through 2500 nm
Pyrex[®]	320 through 2500 nm
Spectrosil[®] Quartz	170 through 2700 nm
Infrasil[®]	220 through 3800 nm

For fluorescent applications, Spectrosil[®] is recommended as it does not exhibit any background fluorescence. Some other materials, especially glass and lower grades of quartz may have some background fluorescence. Standard window thickness is 1.25mm, polished to a flatness tolerance of better than 4 Newton Fringes per centimeter in the viewing area. They are typically flat to better than 1 micron (0.001mm) over the whole window area. The scratch and dig specification for surface polish is 60/40. The meticulous care taken in the preparation and construction of regular quartz fluorescent cells allows for normal tolerances to be sufficiently stringent for use in laser applications.

Cell Matching

The high degree of accuracy maintained during production ensures a standard path length tolerance of +/- 0.01mm. The tolerance maintained for parallelism of the windows is better than 3 minutes of arc, therefore quartz cells vary little in transmission values. Slight differences in the transmission of new glass cells are due to variations in raw material transmission characteristics. The transmission of matched cells is measured and each cell is given a match code. These codes are only of real value when comparing new cells because the transmission characteristics may change as surface contamination or deterioration occurs during normal use. Thus, a new cell of a particular match code will not necessarily match an older cell of the same match code.

Cells which are commonly used (eg. 1-Q-10) are normally supplied from stock in unlimited quantities of the same match code. The less commonly used cells can usually be supplied in matched sets of two or four. In the case of Tablet Dissolution flow cells, matched sets of eight or more can be supplied.

Window Material	Matching Tolerance	Measured at Wavelength
Optical Glass	0.5 %	350 nm
Special Optical Glass	1.0 %	320 nm
Spectrosil Quartz	1.5 %	200 nm
Infrasil Quartz	1.5 %	240 nm

'Z' Dimension for small volumes

The 'Z' dimension is the distance from the base of a cell to the center of the sample chamber window. The 'Z' dimension is very important for small volume cells of any design, where the sample compartment cross section dimension is very small. The correct 'Z' dimension should be added to the part number for small volume cells

'Z' Dimension per Instrument

Manufacturer:	'Z' Dimension:
Agilent®	15 mm
Beckman®	8.5 mm
Bio-Rad®	8.5 mm
Eppendorf®	8.5 mm
GBC®	15 mm
Hewlett Packard®	15 mm
Hitachi®	varies by instrument
Jasco®	11 mm
Ocean Optics®	15 mm
Perkin-Elmer®	15 mm
Pharmacia®	15 mm
Shimadzu®	15 mm
StellarNet®	15 mm
Thermo Spectronic®	8.5 and 15 mm
Turner®	8.5 mm
Varian®	20 mm

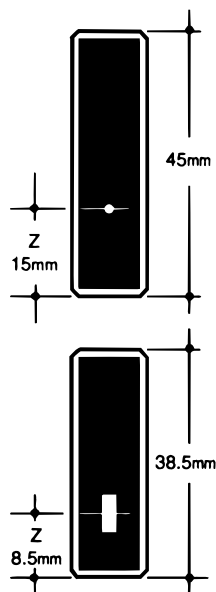

How to determine 'Z' Dimension:

- 1) Cut a piece of paper 12mm x 100mm
- 2) Punch a hole with a pen 15mm from one end and 8.5mm from the other end
- 3) Put your instrument in %T at about 535nm.
- 4) Place the paper in the cell holder and see which hole transmits light through the hole.
- 5) If neither transmits light, cut another piece of paper and try other dimensions from the end of the paper.

For technical questions or
to place orders please call:

USA/Canada: **(800) 228-4482**
 Foreign: **(805) 466-8855**
 FAX : **(805) 461-1575**
 e-mail: **sales@starnacells.com**
 Website: **www.starnacells.com**

or mail orders to:



Starna Cells, Inc.
 PO Box 1919
 Atascadero, CA 93423

Contents:

Spectrophotometer Cells

Closed screw cap	13
Cylindrical	22 - 25
Demountable, short path	14
Demountable, flow	15
Dual pathlength	30
Flow cells	13, 15 - 21
Graded seal attached	35
Low head space	11
Micro volume	8, 9, 12
Mixing Cells	31, 37
Semi-micro volume	6, 7
Septum cap cells	13
Standard rectangular	4, 5
Stirring cells	37
Sub-micro volume	10
Tablet dissolution	17 - 19
Tube attached to cells	35
Ultra-micro volume	12
Water jacket cells	38

Fluorometer Cells

Closed screw cap	31
Dual pathlength	30
Flow cells	32, 33
Graded seal attached	35
Micro volume	26, 27
Micro, square	28
Semi-micro volume	26, 27
Septum cap cells	31
Standard rectangular	26, 27
Stirring cells	37
Sub-micro volume	29
Tandem or Divided	31
Triangular	30
Tube attached to cells	35

Special Cells and Accessories

Cell adapters	7, 24, 28, 39
Coatings, AR and Mirror	39
Colorimeter cells	36
Laser cells	34
Microscope cells	37

Validation sets

UV/Visible reference set	40-43
Fluorescence reference set	33

Standard Rectangular

Standard rectangular cells or Macro cells, Type 1, are the most common cells used in analytical chemistry. The exterior dimensions allow the cells to be used with virtually every spectrophotometer and photometer instrument currently in use.

These cells have an exterior height of 45mm, two clear windows and an open top. The walls of the cell and the bottom are smooth on the inside. On the outside, the light path windows are clear while the adjacent windows and the bottom are frosted or grey. Typically, windows are 1.25mm thick and each cell in this range is supplied with a PTFE cover.

Accessories:

Spacers for the 1, 2, and 5mm pathlength on page 7.

HOLDERS for Infrared instruments are available on page 39.

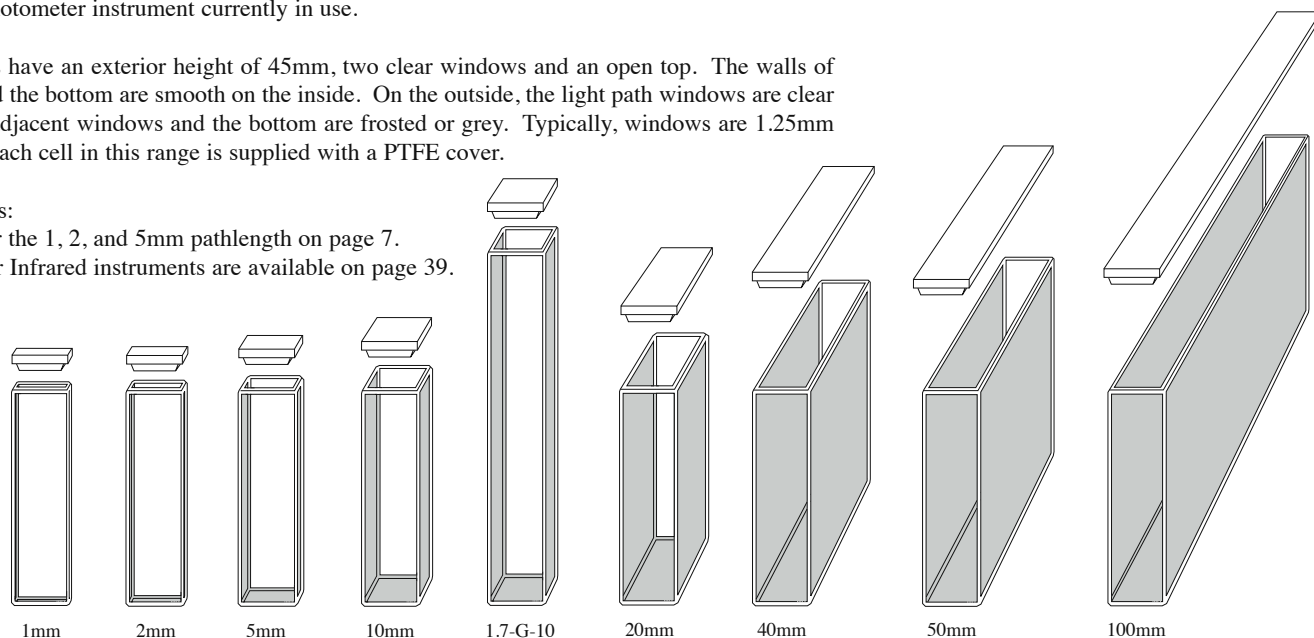

Catalog Number	Path Length mm	Exterior, mm			Interior, mm		Nominal Vol. ml	Polished Windows	Price per cell
		Width	Length	Height	Width	Length			

Optical Glass windows, Useable range: 334 to 2500 nm

1-G-1	1	12.5	3.5	45	10	1	0.400	2	\$49.00
1-G-2	2	12.5	4.5	45	10	2	0.700	2	49.00
1-G-5	5	12.5	7.5	45	10	5	1.700	2	45.00
1-G-10	10	12.5	12.5	45	10	10	3.500	2	35.00
1.7-G-10	10	12.5	12.5	70	10	10	6.500	2	55.00
1-G-20	20	12.5	22.5	45	10	20	7.000	2	49.00
1-G-40	40	12.5	42.5	45	10	40	14.000	2	52.00
1-G-50	50	12.5	52.5	45	9.5	50	17.500	2	79.00
1-G-100	100	12.5	102.5	45	9.5	100	35.000	2	135.00

Special Optical Glass windows, Useable range: 320 to 2500 nm

1-SOG-10	10	12.5	12.5	45	10	10	3.500	2	\$45.00
----------	----	------	------	----	----	----	-------	---	---------

Spectrosil® Far UV Quartz windows, Useable range: 170 to 2700 nm

1-Q-1	1	12.5	3.5	45	10	1	0.400	2	\$ 109.00
1-Q-2	2	12.5	4.5	45	10	2	0.700	2	109.00
1-Q-5	5	12.5	7.5	45	10	5	1.700	2	99.00
1-Q-10	10	12.5	12.5	45	10	10	3.500	2	79.00
1-Q-20	20	12.5	22.5	45	10	20	7.000	2	119.00
1-Q-40	40	12.5	42.5	45	10	40	14.00	2	155.00
1-Q-50	50	12.5	52.5	45	9.5	50	17.500	2	179.00
1-Q-100	100	12.5	102.5	45	9.5	100	35.000	2	305.00

Infracel® or equivalent Near Infrared Quartz windows, Useable range: 220 to 3800 nm

1-I-1	1	12.5	3.5	45	10	1	0.400	2	\$ 125.00
1-I-2	2	12.5	4.5	45	10	2	0.700	2	125.00
1-I-5	5	12.5	7.5	45	10	5	1.700	2	115.00
1-I-10	10	12.5	12.5	45	10	10	3.500	2	105.00
1-I-20	20	12.5	22.5	45	10	20	7.000	2	145.00
1-I-40	40	12.5	42.5	45	10	40	14.00	2	219.00
1-I-50	50	12.5	52.5	45	9.5	50	17.500	2	235.00
1-I-100	100	12.5	102.5	45	9.5	100	35.000	2	355.00

Standard Rectangular with stopper

Type 21 cells are identical to Standard Rectangular or Macro cells listed on page 4, except that instead of having an open rectangular hole at the top, a block is fused to the top of the cell with a ground hole to receive a PTFE stopper. This provides a more suitable seal for volatile liquids.

Cells with a path length of greater than 20mm are supplied with two stoppers and the height of the cell body is 48 mm with an overall height including the stopper of approximately 53mm.

Accessories:

Spacers for the 1, 2, and 5mm pathlength on page 7.

HOLDERS for Infrared instruments are available on page 39.

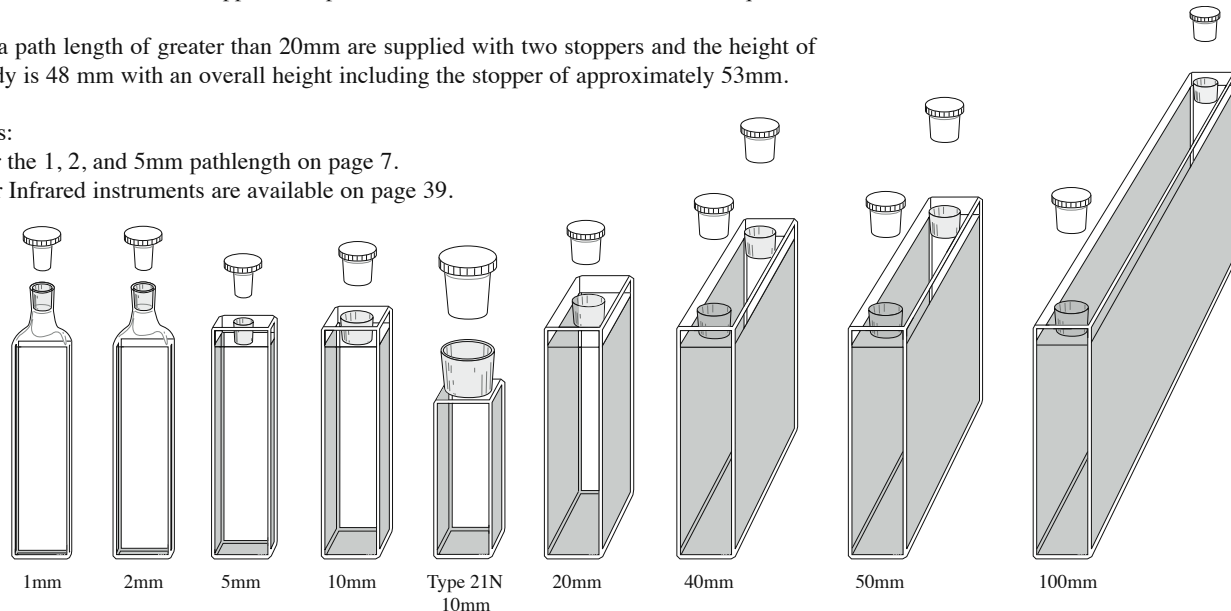

Catalog Number	Path Length mm	Exterior, mm			Interior, mm		Nominal Vol. ml	Number of Stoppers	Polished Windows	Price per cell
		Width	Length	Height	Width	Length				

Optical Glass windows, Useable range: 334 to 2500 nm

21-G-1	1	12.5	3.5	55	10	1	0.400	1	2	\$ 85.00
21-G-2	2	12.5	4.5	55	10	2	0.700	1	2	85.00
21-G-5	5	12.5	7.5	48	10	5	1.700	1	2	79.00
21-G-10	10	12.5	12.5	48	10	10	3.500	1	2	69.00
21-G-20	20	12.5	22.5	48	10	20	7.000	1	2	85.00
21-G-40	40	12.5	42.5	48	10	40	14.00	2	2	105.00
21-G-50	50	12.5	52.5	48	9.5	50	17.500	2	2	115.00
21-G-100	100	12.5	102.5	48	9.5	100	35.000	2	2	229.00

Special Optical Glass windows, Useable range: 320 to 2500 nm

21-SOG-10	10	12.5	12.5	48	10	10	3.500	1	2	\$ 79.00
-----------	----	------	------	----	----	----	-------	---	---	----------

Spectrosil® Far UV Quartz windows, Useable range: 170 to 2700 nm

21-Q-1	1	12.5	3.5	55	10	1	0.400	1	2	\$ 139.00
21-Q-2	2	12.5	4.5	55	10	2	0.700	1	2	139.00
21-Q-5	5	12.5	7.5	48	10	5	1.700	1	2	135.00
21-Q-10	10	12.5	12.5	48	10	10	3.500	1	2	109.00
21N-Q-10	10	12.5	12.5	44	10	10	3.000	1	2	125.00
21-Q-20	20	12.5	22.5	48	10	20	7.000	1	2	159.00
21-Q-40	40	12.5	42.5	48	10	40	14.00	2	2	239.00
21-Q-50	50	12.5	52.5	48	9.5	50	17.500	2	2	259.00
21-Q-100	100	12.5	102.5	48	9.5	100	35.000	2	2	425.00

Infrasil® or equivalent Near Infrared Quartz windows, Useable range: 220 to 3800 nm

21-I-1	1	12.5	3.5	55	10	1	0.400	1	2	\$ 149.00
21-I-2	2	12.5	4.5	55	10	2	0.700	1	2	149.00
21-I-5	5	12.5	7.5	48	10	5	1.700	1	2	145.00
21-I-10	10	12.5	12.5	48	10	10	3.500	1	2	129.00
21-I-20	20	12.5	22.5	48	10	20	7.000	1	2	169.00
21-I-40	40	12.5	42.5	48	10	40	14.00	2	2	249.00
21-I-50	50	12.5	52.5	48	9.5	50	17.500	2	2	269.00
21-I-100	100	12.5	102.5	48	9.5	100	35.000	2	2	435.00

Semi-Micro

The purpose of Semi-Micro Type 9 cells is to reduce the sample volume necessary to make a measurement. The volume of a Semi-Micro cell is approximately 40% of an equivalent path length standard rectangular cell.

Semi-Micro cells are available with either clear walls parallel to the light beam or non transmitting self masking black walls which improve sensitivity by eliminating stray light from measurements. The interior sample compartment width of Semi-Micro cells is reduced to 4mm, therefore it is essential to determine that the light beam from the instrument passes centrally through the sample compartment. This is especially important for long path length cells. Both the Type 9 and Type 9B are supplied with a PTFE cover (not pictured with the Type 9B or 9B9).

Smaller sample volumes can be achieved by using cell Type 9/9 or 9B9 with a 9mm instead of a 3mm thick base. *Note: Cells with a 9mm base are not suitable for an instrument with an 8.5mm 'Z' dimension.*

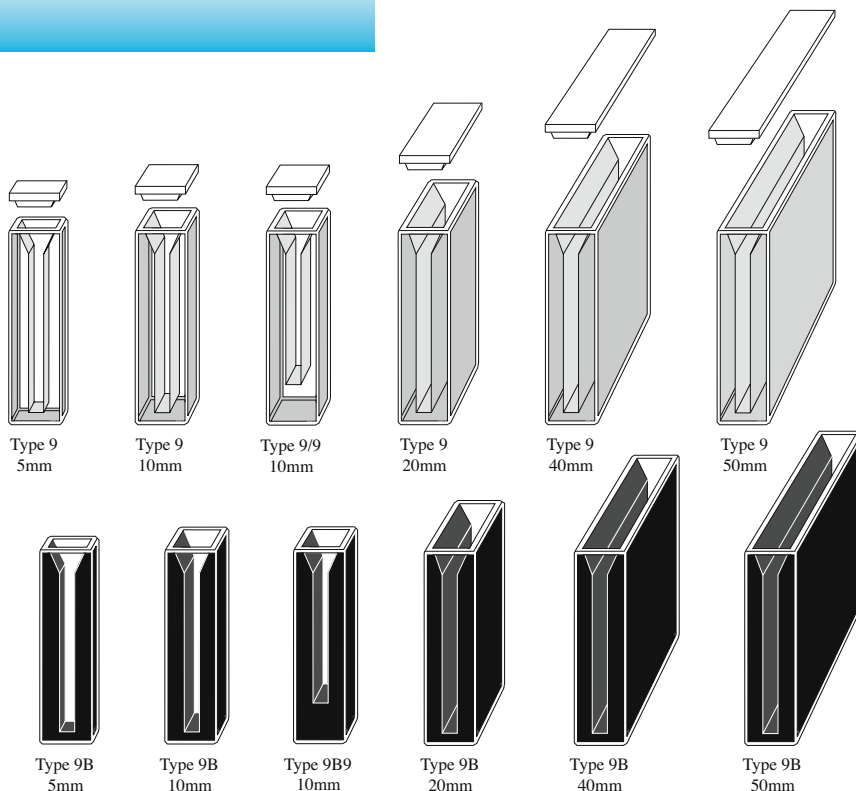

Catalog Number	Path Length mm	Exterior, mm			Interior, mm		Nominal Vol. ml	Polished Windows	Price per cell
		Width	Length	Height	Width	Length			
<i>Special Optical Glass windows, Useable range: 320 to 2500 nm</i>									
<i>Clear Walls</i>									
9-SOG-5	5	12.5	7.5	45	4	5	0.700	2	\$ 69.00
9-SOG-10	10	12.5	12.5	45	4	10	1.400	2	65.00
9/9-SOG-10	10	12.5	12.5	45	4	10	1.160	2	89.00
9-SOG-20	20	12.5	22.5	45	4	20	2.800	2	85.00
9-SOG-40	40	12.5	42.5	45	4	40	5.600	2	105.00
9-SOG-50	50	12.5	52.5	45	4	50	7.000	2	115.00
<i>Spectrosil® Far UV Quartz windows, Useable range: 170 to 2700 nm</i>									
9-Q-5	5	12.5	7.5	45	4	5	0.700	2	\$ 129.00
9-Q-10	10	12.5	12.5	45	4	10	1.400	2	119.00
9/9-Q-10	10	12.5	12.5	45	4	10	1.160	2	145.00
9-Q-20	20	12.5	22.5	45	4	20	2.800	2	159.00
9-Q-40	40	12.5	42.5	45	4	40	5.600	2	199.00
9-Q-50	50	12.5	52.5	45	4	50	7.000	2	209.00
<i>Special Optical Glass windows, Useable range: 320 to 2500 nm</i>									
<i>Black Walls, Self Masking</i>									
9B-SOG-5	5	12.5	7.5	45	4	5	0.700	2	\$ 105.00
9B-SOG-10	10	12.5	12.5	45	4	10	1.400	2	95.00
9B9-SOG-10	10	12.5	12.5	45	4	10	1.160	2	105.00
9B-SOG-20	20	12.5	22.5	45	4	20	2.800	2	119.00
9B-SOG-40	40	12.5	42.5	45	4	40	5.600	2	165.00
9B-SOG-50	50	12.5	52.5	45	4	50	7.000	2	199.00
<i>Spectrosil® Far UV Quartz windows, Useable range: 170 to 2700 nm</i>									
9B-Q-5	5	12.5	7.5	45	4	5	0.700	2	\$ 229.00
9B-Q-10	10	12.5	12.5	45	4	10	1.400	2	195.00
9B9-Q-10	10	12.5	12.5	45	4	10	1.160	2	239.00
9B-Q-20	20	12.5	22.5	45	4	20	2.800	2	285.00
9B-Q-40	40	12.5	42.5	45	4	40	5.600	2	389.00
9B-Q-50	50	12.5	52.5	45	4	50	7.000	2	479.00

Semi-Micro with stopper

Similar in all respects to the Type 9 Semi-Micro cells, with the exception that these cells are supplied with a PTFE stopper, or stoppers as pictured, to fit in a ground fitting to reduce evaporation of volatile samples (The Type 29B comes with stoppers even though the stoppers are not pictured). The Type 29 and Type 29B cells have an external height of 48 mm plus stopper.

Smaller sample volumes can be achieved by using cell Type 29/9 or 29B9 with a 9mm instead of a 3mm thick base.

Note: Cells with a 9mm base are not suitable for an instrument with an 8.5mm 'Z' dimension.

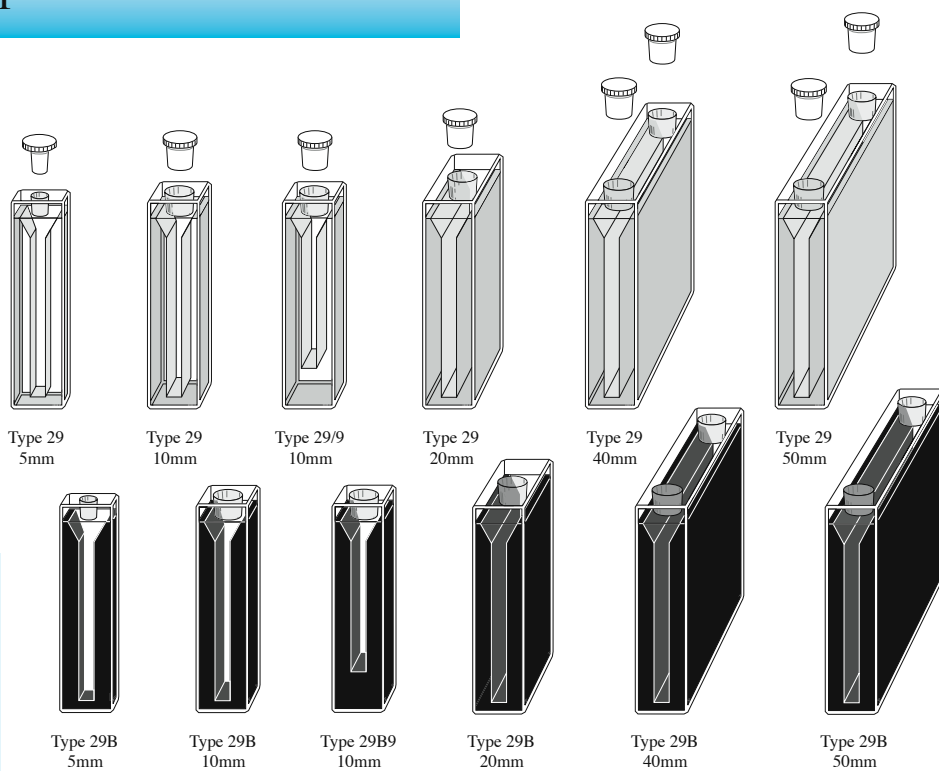

Short Pathlength Spacers

Black anodized aluminum spacers are available in three sizes for use with 1, 2, and 5mm path length cells, supporting them in a normal 12.5 x 12.5mm holder where there is no cell holder path length adjustment facility.

Cat. No	Description	Price, each
SPA-1	for 1mm path length cells	\$ 52.00
SPA-2	for 2mm path length cells	52.00
SPA-5	for 5mm path length cells	52.00



Catalog Number	Path Length mm	Exterior, mm			Interior, mm		Nominal Vol. ml	Polished Windows	Price per cell
		Width	Length	Height	Width	Length			
<i>Special Optical Glass windows, Useable range: 320 to 2500 nm</i>									
29-SOG-5	5	12.5	7.5	48	4	5	0.700	2	\$ 139.00
29-SOG-10	10	12.5	12.5	48	4	10	1.400	2	105.00
29/9-SOG-10	10	12.5	12.5	48	4	10	1.160	2	169.00
29-SOG-20	20	12.5	22.5	48	4	20	2.800	2	169.00
29-SOG-40	40	12.5	42.5	48	4	40	5.600	2	209.00
29-SOG-50	50	12.5	52.5	48	4	50	7.000	2	239.00
<i>Spectrosil® Far UV Quartz windows, Useable range: 170 to 2700 nm</i>									
29-Q-5	5	12.5	7.5	48	4	5	0.700	2	\$ 165.00
29-Q-10	10	12.5	12.5	48	4	10	1.400	2	145.00
29/9-Q-10	10	12.5	12.5	48	4	10	1.160	2	199.00
29-Q-20	20	12.5	22.5	48	4	20	2.800	2	209.00
29-Q-40	40	12.5	42.5	48	4	40	5.600	2	259.00
29-Q-50	50	12.5	52.5	48	4	50	7.000	2	309.00
<i>Special Optical Glass windows, Useable range: 320 to 2500 nm</i>									
29B-SOG-5	5	12.5	7.5	48	4	5	0.700	2	\$ 165.00
29B-SOG-10	10	12.5	12.5	48	4	10	1.400	2	135.00
29B9-SOG-10	10	12.5	12.5	48	4	10	1.160	2	189.00
29B-SOG-20	20	12.5	22.5	48	4	20	2.800	2	205.00
29B-SOG-40	40	12.5	42.5	48	4	40	5.600	2	265.00
29B-SOG-50	50	12.5	52.5	48	4	50	7.000	2	285.00
<i>Spectrosil® Far UV Quartz windows, Useable range: 170 to 2700 nm</i>									
29B-Q-5	5	12.5	7.5	48	4	5	0.700	2	\$ 259.00
29B-Q-10	10	12.5	12.5	48	4	10	1.400	2	229.00
29B9-Q-10	10	12.5	12.5	48	4	10	1.160	2	259.00
29B-Q-20	20	12.5	22.5	48	4	20	2.800	2	339.00
29B-Q-40	40	12.5	42.5	48	4	40	5.600	2	459.00
29B-Q-50	50	12.5	52.5	48	4	50	7.000	2	539.00

Micro Cells

Micro cells, Type 18, with a 2mm internal width are for use with sample volumes smaller than the standard rectangular or Semi-Micro cells. The nominal working volume of this range represents only 20% of the standard rectangular cells Type 1 with the same path length.

Micro cells are available with either clear walls or black walls which are opaque and improve sensitivity. The cells have an exterior height of 45mm. Each cell has an open top and is supplied with a PTFE cover (not pictured with the Type 18B or 18B9).

Smaller sample volumes can be achieved by using cell Type 18/9 or 18B9 with a 9mm instead of a 3mm thick base.

Note: Cells with a 9mm base are not suitable for instruments with an 8.5mm 'Z' dimension.

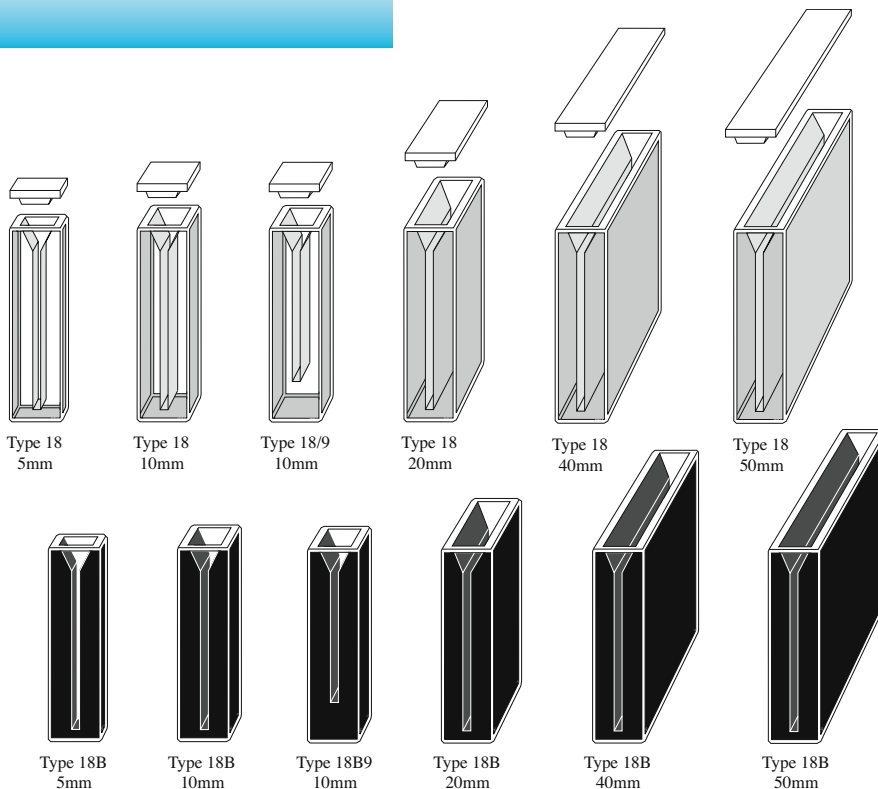

Catalog Number	Path Length mm	Exterior, mm			Interior, mm		Nominal Vol. ml	Polished Windows	Price per cell
		Width	Length	Height	Width	Length			
<i>Special Optical Glass windows, Useable range: 320 to 2500 nm</i>									
<i>Clear Walls</i>									
18-SOG-5	5	12.5	7.5	45	2	5	0.350	2	\$ 79.00
18-SOG-10	10	12.5	12.5	45	2	10	0.700	2	69.00
18/9-SOG-10	10	12.5	12.5	45	2	10	0.580	2	95.00
18-SOG-20	20	12.5	22.5	45	2	20	1.400	2	99.00
18-SOG-40	40	12.5	42.5	45	2	40	2.800	2	119.00
18-SOG-50	50	12.5	52.5	45	2	50	3.500	2	139.00
<i>Spectrosil® Far UV Quartz windows, Useable range: 170 to 2700 nm</i>									
18-Q-5	5	12.5	7.5	45	2	5	0.350	2	\$ 139.00
18-Q-10	10	12.5	12.5	45	2	10	0.700	2	125.00
18/9-Q-10	10	12.5	12.5	45	2	10	0.580	2	159.00
18-Q-20	20	12.5	22.5	45	2	20	1.400	2	165.00
18-Q-40	40	12.5	42.5	45	2	40	2.800	2	205.00
18-Q-50	50	12.5	52.5	45	2	50	3.500	2	225.00
<i>Special Optical Glass windows, Useable range: 320 to 2500 nm</i>									
<i>Black Walls, Self Masking</i>									
18B-SOG-5	5	12.5	7.5	45	2	5	0.350	2	\$ 105.00
18B-SOG-10	10	12.5	12.5	45	2	10	0.700	2	89.00
18B9-SOG-10	10	12.5	12.5	45	2	10	0.580	2	119.00
18B-SOG-20	20	12.5	22.5	45	2	20	1.400	2	129.00
18B-SOG-40	40	12.5	42.5	45	2	40	2.800	2	159.00
18B-SOG-50	50	12.5	52.5	45	2	50	3.500	2	175.00
<i>Spectrosil® Far UV Quartz windows, Useable range: 170 to 2700 nm</i>									
18B-Q-5	5	12.5	7.5	45	2	5	0.350	2	\$ 239.00
18B-Q-10	10	12.5	12.5	45	2	10	0.700	2	209.00
18B9-Q-10	10	12.5	12.5	45	2	10	0.580	2	239.00
18B-Q-20	20	12.5	22.5	45	2	20	1.400	2	289.00
18B-Q-40	40	12.5	42.5	45	2	40	2.800	2	419.00
18B-Q-50	50	12.5	52.5	45	2	50	3.500	2	595.00

Micro Cells with stopper

Type 28 cells are identical to Type 18 Micro cells, except these cells are supplied with a PTFE stopper, or stoppers as pictured, to fit in a ground cone to reduce evaporation of volatile samples (The Type 28B comes with stoppers even though the stoppers are not pictured). The external height is 48mm plus the stopper. Micro cells are available with either clear walls which will transmit energy or opaque black walls for improved sensitivity. Alignment of Micro cells in instrument cell holders is critical.

Smaller sample volumes can be achieved by using cell Type 28/9 or 28B9 with a 9mm instead of a 3mm thick base.

Note: Cells with a 9mm base are not suitable for instruments with an 8.5mm 'Z' dimension.

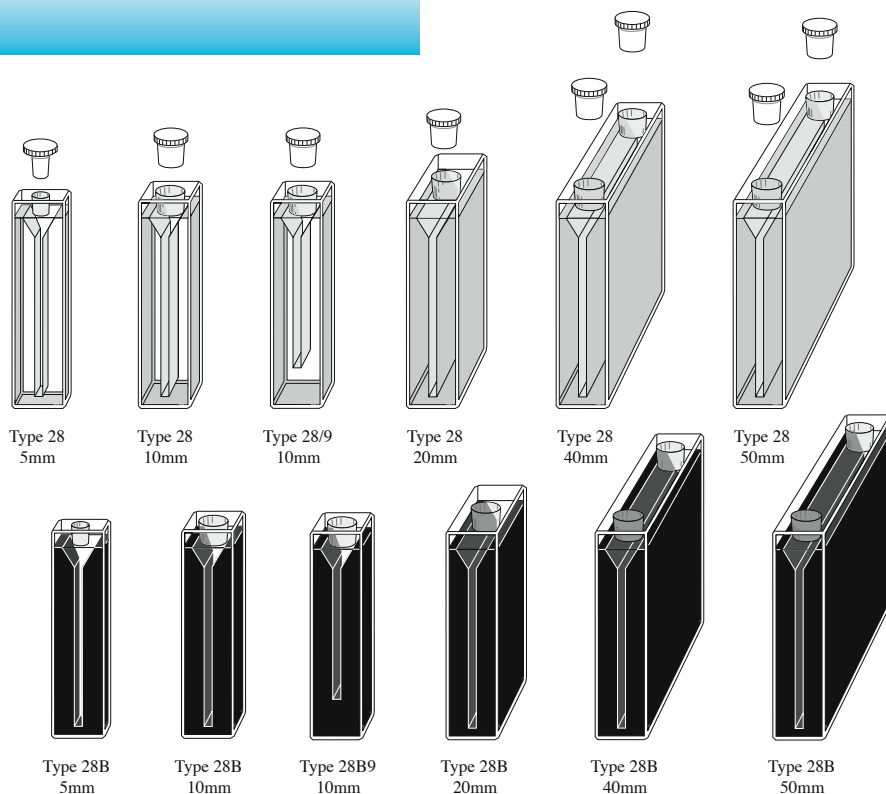

Short Pathlength Spacers

Black anodized aluminum spacers are available in three sizes for use with 1, 2, and 5mm path length cells, supporting them in a normal 12.5 x 12.5mm holder where there is no cell holder path length adjustment facility.

Cat. No	Description	Price, each
SPA-1	for 1mm path length cells	\$ 52.00
SPA-2	for 2mm path length cells	52.00
SPA-5	for 5mm path length cells	52.00

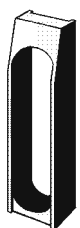

Catalog Number	Path Length mm	Exterior, mm			Interior, mm		Nominal Vol. ml	Polished Windows	Price per cell
		Width	Length	Height	Width	Length			
<i>Special Optical Glass windows, Useable range: 320 to 2500 nm</i>									
<i>Clear Walls</i>									
28-SOG-5	5	12.5	7.5	48	2	5	0.350	2	\$ 145.00
28-SOG-10	10	12.5	12.5	48	2	10	0.700	2	129.00
28/9-SOG-10	10	12.5	12.5	48	2	10	0.580	2	165.00
28-SOG-20	20	12.5	22.5	48	2	20	1.400	2	175.00
28-SOG-40	40	12.5	42.5	48	2	40	2.800	2	225.00
28-SOG-50	50	12.5	52.5	48	2	50	3.500	2	245.00
<i>Spectrosil® Far UV Quartz windows, Useable range: 170 to 2700 nm</i>									
28-Q-5	5	12.5	7.5	48	2	5	0.350	2	\$ 175.00
28-Q-10	10	12.5	12.5	48	2	10	0.700	2	165.00
28/9-Q-10	10	12.5	12.5	48	2	10	0.580	2	185.00
28-Q-20	20	12.5	22.5	48	2	20	1.400	2	215.00
28-Q-40	40	12.5	42.5	48	2	40	2.800	2	279.00
28-Q-50	50	12.5	52.5	48	2	50	3.500	2	305.00
<i>Special Optical Glass windows, Useable range: 320 to 2500 nm</i>									
<i>Black Walls, Self Masking</i>									
28B-SOG-5	5	12.5	7.5	48	2	5	0.350	2	\$175.00
28B-SOG-10	10	12.5	12.5	48	2	10	0.700	2	149.00
28B9-SOG-10	10	12.5	12.5	48	2	10	0.580	2	199.00
28B-SOG-20	20	12.5	22.5	48	2	20	1.400	2	215.00
28B-SOG-40	40	12.5	42.5	48	2	40	2.800	2	275.00
28B-SOG-50	50	12.5	52.5	48	2	50	3.500	2	345.00
<i>Spectrosil® Far UV Quartz windows, Useable range: 170 to 2700 nm</i>									
28B-Q-5	5	12.5	7.5	48	2	5	0.350	2	\$ 299.00
28B-Q-10	10	12.5	12.5	48	2	10	0.700	2	249.00
28B9-Q-10	10	12.5	12.5	48	2	10	0.580	2	285.00
28B-Q-20	20	12.5	22.5	48	2	20	1.400	2	375.00
28B-Q-40	40	12.5	42.5	48	2	40	2.800	2	595.00
28B-Q-50	50	12.5	52.5	48	2	50	3.500	2	649.00

Sub-Micro Cells

Sub-Micro cells retain the exterior dimensions of a standard cell and are designed for the measurement of very small samples, with volumes ranging from 10 μ l to 160 μ l. The entrance to the sample compartment is hemispherical, being designed without sharp corners to eliminate potential loss of sample due to capillary action.

The amount of sample required to fill the sample chamber is reduced to an absolute minimum, typically fifteen to twenty per cent greater than the absolute sample chamber volume.

The sample compartment in the Sub-Micro range of cells optimizes the alignment of the sample for maximum sensitivity in the spectrophotometer. The sample is easily inserted into and retrieved from the cell, by careful use of a pipette. The correct 'Z' dimension needs to be selected for this range, typically 8.5 or 15mm.

Cells are supplied with a PTFE cover and a tight sealing polypropylene cap.

'Z' Dimension per Instrument

Manufacturer:	'Z' Dimension:
Agilent [®]	15 mm
Beckman [®]	8.5 mm
Bio-Rad [®]	8.5 mm
Eppendorf [®]	8.5 mm
GBC [®]	15 mm
Hewlett Packard [®]	15 mm
Hitachi [®]	varies by instrument
Jasco [®]	12 mm
Ocean Optics [®]	15 mm
Perkin-Elmer [®]	15 mm
Pharmacia [®]	15 mm
Shimadzu [®]	15 mm
StellarNet [®]	15 mm
Thermo Spectronic [®]	8.5 and 15 mm
Turner [®]	8.5 mm
Varian [®]	20 mm

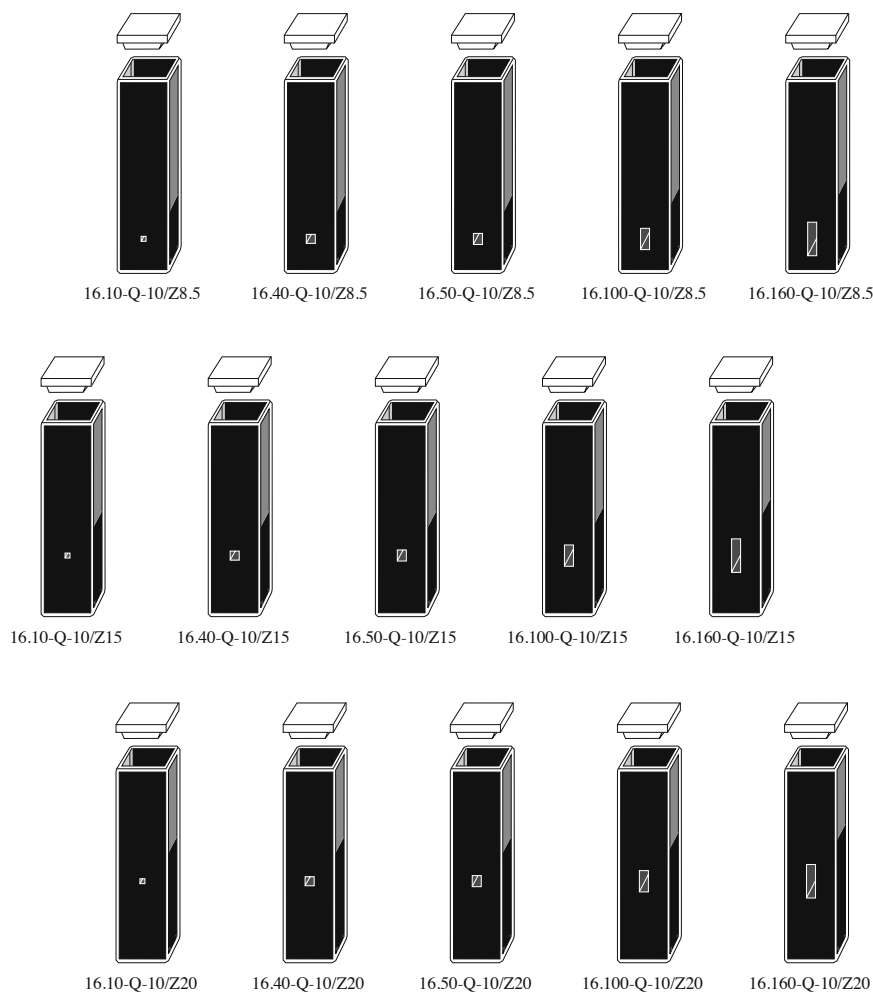

Catalog Number	Path Length		Exterior, mm		Sample Chamber, mm			'Z' Dim. mm	Nominal Vol. ml	Polished Windows	Price per cell
	mm	mm	Width	Length	Height	Width	Length				
<i>Spectrosil[®] Far UV Quartz windows, Useable range: 170 to 2700 nm</i>											
<i>Sub-Micro, Open Top</i>											
16.10-Q-10/Z8.5	10	12.5	12.5	45	1	10	1	8.5	0.010	2	\$ 295.00
16.10-Q-10/Z15	10	12.5	12.5	45	1	10	1	15	0.010	2	295.00
16.10-Q-10/Z20	10	12.5	12.5	45	1	10	1	20	0.010	2	295.00
16.40-Q-10/Z8.5	10	12.5	12.5	45	2	10	2	8.5	0.040	2	259.00
16.40-Q-10/Z15	10	12.5	12.5	45	2	10	2	15	0.040	2	259.00
16.40-Q-10/Z20	10	12.5	12.5	45	2	10	2	20	0.040	2	259.00
16.50-Q-10/Z8.5	10	12.5	12.5	45	2	10	2.5	8.5	0.050	2	259.00
16.50-Q-10/Z15	10	12.5	12.5	45	2	10	2.5	15	0.050	2	259.00
16.50-Q-10/Z20	10	12.5	12.5	45	2	10	2.5	20	0.050	2	259.00
16.100-Q-10/Z8.5	10	12.5	12.5	45	2	10	5	8.5	0.100	2	259.00
16.100-Q-10/Z15	10	12.5	12.5	45	2	10	5	15	0.100	2	259.00
16.100-Q-10/Z20	10	12.5	12.5	45	2	10	5	20	0.100	2	259.00
16.160-Q-10/Z8.5	10	12.5	12.5	45	2	10	8	8.5	0.160	2	259.00
16.160-Q-10/Z15	10	12.5	12.5	45	2	10	8	15	0.160	2	259.00
16.160-Q-10/Z20	10	12.5	12.5	45	2	10	8	20	0.160	2	259.00

Low Head Space Cells, Thermal Melt

Low head space Sub-Micro cells are designed for thermal melt. The low head space cells hold volumes ranging from 10 μ l to 160 μ l while retaining standard exterior dimensions. The entrance to the sample compartment is hemispherical, being designed without sharp corners to eliminate potential loss of sample due to capillary action.

Cells are supplied with a special PTFE stopper. The liquid tight stopper reduces the volume of air by 95% over the volume of the sub-micro cells on the previous page.

The sample compartment in the Sub-Micro range of cells optimizes the alignment of the sample for maximum sensitivity in the spectrophotometer. The sample is easily inserted into and retrieved from the cell, by careful use of a pipette. The correct 'Z' dimension needs to be selected for this range, typically 8.5, 15 or 20mm.

The amount of sample required to fill the sample chamber is reduced to an absolute minimum, typically fifteen to twenty per cent greater than the absolute sample chamber volume.

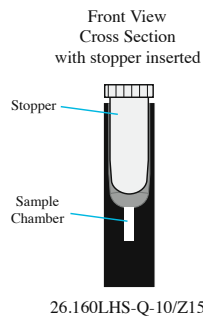
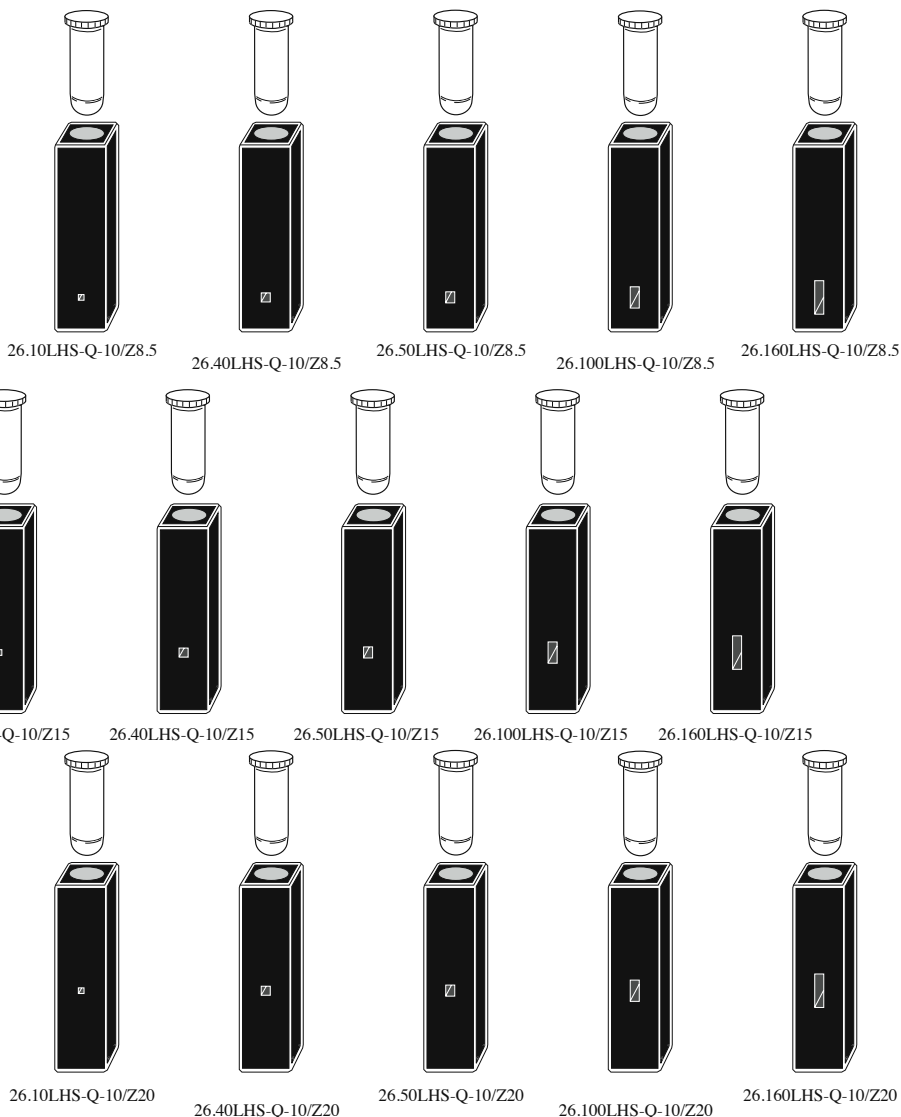

Catalog Number	Path Length mm	Exterior, mm			Sample Chamber, mm			'Z' Dim mm	Nominal Vol. ml	Polished Windows	Price per cell
		Width	Length	Height	Width	Length	Height				
26.10LHS-Q-10/Z8.5	10	12.5	12.5	45	1	10	1	8.5	0.010	2	\$ 509.00
26.10LHS-Q-10/Z15	10	12.5	12.5	45	1	10	1	15	0.010	2	509.00
26.10LHS-Q-10/Z20	10	12.5	12.5	45	1	10	1	20	0.010	2	509.00
26.40LHS-Q-10/Z8.5	10	12.5	12.5	45	2	10	2	8.5	0.040	2	445.00
26.40LHS-Q-10/Z15	10	12.5	12.5	45	2	10	2	15	0.040	2	445.00
26.40LHS-Q-10/Z20	10	12.5	12.5	45	2	10	2	20	0.040	2	445.00
26.50LHS-Q-10/Z8.5	10	12.5	12.5	45	2	10	2.5	8.5	0.050	2	445.00
26.50LHS-Q-10/Z15	10	12.5	12.5	45	2	10	2.5	15	0.050	2	445.00
26.50LHS-Q-10/Z20	10	12.5	12.5	45	2	10	2.5	20	0.050	2	445.00
26.100LHS-Q-10/Z8.5	10	12.5	12.5	45	2	10	5	8.5	0.100	2	445.00
26.100LHS-Q-10/Z15	10	12.5	12.5	45	2	10	5	15	0.100	2	445.00
26.100LHS-Q-10/Z20	10	12.5	12.5	45	2	10	5	20	0.100	2	445.00
26.160LHS-Q-10/Z8.5	10	12.5	12.5	45	2	10	8	8.5	0.160	2	445.00
26.160LHS-Q-10/Z15	10	12.5	12.5	45	2	10	8	15	0.160	2	445.00
26.160LHS-Q-10/Z20	10	12.5	12.5	45	2	10	8	20	0.160	2	445.00

Spectrosil® Far UV Quartz windows, Useable range: 170 to 2700 nm

Ultra-Micro, Pipette filling

Micro Cells Short & Ultra-Micro Cells

Type 17 Micro cells are similar to Type 18 Micro cells except that the external height is only 25mm. Because of their reduced height, it is essential that the correct micro cell holder is used for the instrument, otherwise it will be difficult to remove the cells from the cell holder. Both black wall self masking cells and clear wall cells are available in this range. Each cell has an open top and is supplied with a PTFE cover.

The configuration of the small sample compartment in the Type 19 Ultra-Micro cell range optimizes the alignment of the sample for maximum sensitivity in the spectrophotometer. The sample is easily inserted into and retrieved from the cell by careful use of a pipette or syringe.

The correct 'Z' Dimension must be selected for the Type 19, normally either 8.5 or 15 mm. The overall height of the 8.5 and 15mm 'Z' cell is 40mm.

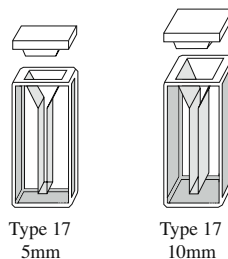
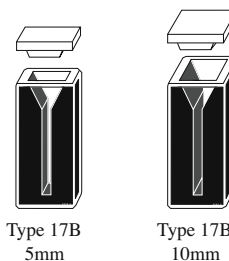

Z Dimension per Instrument

Manufacturer:	Z Dimension:
Agilent®	15 mm
Beckman®	8.5 mm
Bio-Rad®	8.5 mm
Eppendorf®	8.5 mm
GBC®	15 mm
Hewlett Packard®	15 mm
Hitachi®	varies by instrument
Jasco®	12 mm
Ocean Optics®	15 mm
Perkin-Elmer®	15 mm
Pharmacia®	15 mm
Shimadzu®	15 mm
StellarNet®	15 mm
Thermo Spectronic®	8.5 and 15 mm
Turner®	8.5 mm
Varian®	20 mm

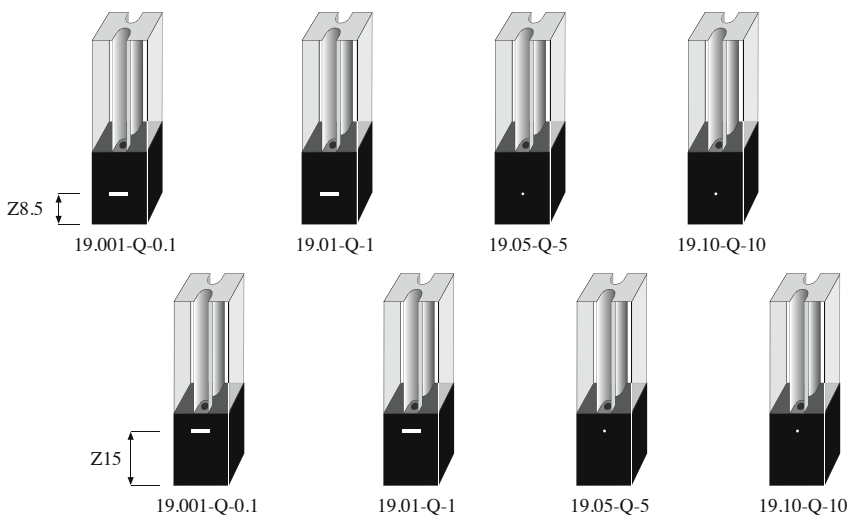

Catalog Number	Path length mm	Exterior, mm			Interior, mm		Nominal Vol. ml	Polished Windows	Price per cell
		Width	Length	Height	Width	Length			

Spectrosil® Far UV Quartz windows, Useable range: 170 to 2700 nm

17-Q-5	5	12.5	7.5	25	2	5	0.200	2	\$ 125.00
17-Q-10	10	12.5	12.5	25	2	10	0.400	2	109.00

Spectrosil® Far UV Quartz windows, Useable range: 170 to 2700 nm

								<i>BlackWalls, Self Masking</i>	
17B-Q-5	5	12.5	7.5	25	2	5	0.200	2	\$ 189.00
17B-Q-10	10	12.5	12.5	25	2	10	0.400	2	169.00

Catalog Number	Path Length mm	Exterior, mm			Sample Chamber, mm			'Z' Dim mm	Nominal Vol. ml	Polished Windows	Price per cell
		Width	Length	Height	Width	Length	Height				

Spectrosil® Far UV Quartz windows, Useable range: 170 to 2700 nm

								<i>Ultra-Micro, Pipette filling</i>			
19.001-Q-0.1/Z8.5	0.1	12.5	12.5	40	5	0.1	1	8.5	0.0005	2	\$ 599.00
19.001-Q-0.1/Z15	0.1	12.5	12.5	40	5	0.1	1	15	0.0005	2	599.00
19.01-Q-1/Z8.5	1	12.5	12.5	40	5	1	1	8.5	0.0050	2	545.00
19.01-Q-1/Z15	1	12.5	12.5	40	5	1	1	15	0.0050	2	545.00
19.05-Q-5/Z8.5	5	12.5	12.5	40	0.8 Ø	5		8.5	0.0025	2	535.00
19.05-Q-5/Z15	5	12.5	12.5	40	0.8 Ø	5		15	0.0025	2	535.00
19.10-Q-10/Z8.5	10	12.5	12.5	40	0.8 Ø	10		8.5	0.0050	2	505.00
19.10-Q-10/Z15	10	12.5	12.5	40	0.8 Ø	10		15	0.0050	2	505.00

Screw Cap Cells, Closed and Septum

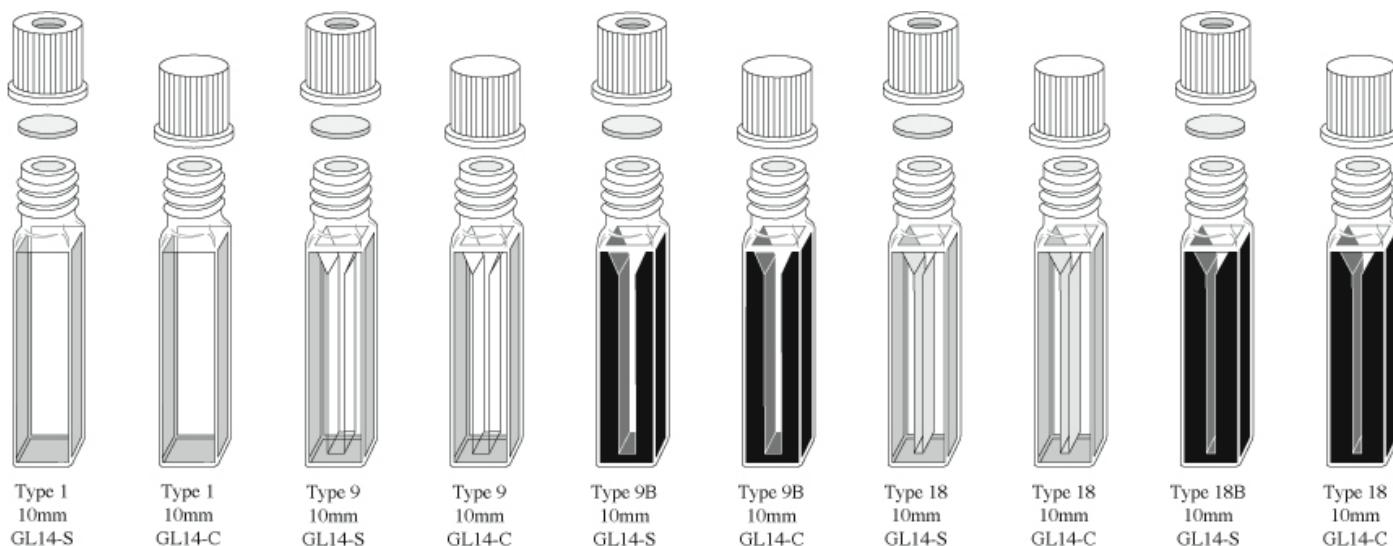

Cell types with suffix **GL14** are able to be used under anaerobic conditions. Cells designated with **GL14** have a standard GL14 threaded top and cap which can be either a septum cap GL14-S or a plain closed cap GL14-C. Each cap contains a silicon seal to give you an air tight fit.

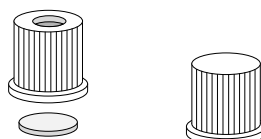

GL14 Caps, Closed & Septum

Screw caps to fit GL14 threaded cells. Available as either closed cap or septum seal cap.

Cat. No	Description	Price, each
GL14-C	Closed cap	\$ 4.25
GL14-S	Septum seal cap	4.25
GL14/SI	Septum Insert	1.50

Catalog Number	Description	Path Length mm	Exterior, mm Width	Exterior, mm Length	Exterior, mm Height	Interior, mm Width	Interior, mm Length	Nominal Vol. ml	Polished Windows	Price per cell
----------------	-------------	----------------	--------------------	---------------------	---------------------	--------------------	---------------------	-----------------	------------------	----------------

Screw Cap Cells with Closed Cap:

Special Optical Glass windows, Useable range: 320 to 2500 nm

1-SOG-10-GL14-C	Closed Cap, Standard	10	12.5	12.5	68	10	10	3.500	2	\$ 119.00
9-SOG-10-GL14-C	Closed Cap, Semi-Micro	10	12.5	12.5	68	4	10	1.400	2	139.00
18-SOG-10-GL14-C	Closed Cap, Micro	10	12.5	12.5	68	2	10	0.700	2	185.00

Spectrosil® Far UV Quartz windows, Useable range: 170 to 2700 nm

1-Q-10-GL14-C	Closed Cap, Standard	10	12.5	12.5	68	10	10	3.500	2	\$ 165.00
9-Q-10-GL14-C	Closed Cap, Semi-Micro	10	12.5	12.5	68	4	10	1.400	2	219.00
9B-Q-10-GL14-C	Semi-Micro, Black Wall	10	12.5	12.5	68	4	10	1.400	2	315.00
18-Q-10-GL14-C	Micro	10	12.5	12.5	68	2	10	0.700	2	269.00
18B-Q-10-GL14-C	Micro, Black Wall	10	12.5	12.5	68	2	10	0.700	2	359.00

Screw Cap Cells with Septum Caps:

Special Optical Glass windows, Useable range: 320 to 2500 nm

1-SOG-10-GL14-S	Septum Cap, Standard	10	12.5	12.5	68	10	10	3.500	2	\$ 119.00
9-SOG-10-GL14-S	Septum Cap, Semi-Micro	10	12.5	12.5	68	4	10	1.400	2	139.00
18-SOG-10-GL14-S	Septum Cap, Micro	10	12.5	12.5	68	2	10	0.700	2	185.00

Spectrosil® Far UV Quartz windows, Useable range: 170 to 2700 nm

1-Q-10-GL14-S	Septum Cap, Standard	10	12.5	12.5	68	10	10	3.500	2	\$ 165.00
9-Q-10-GL14-S	Septum Cap, Semi-Micro	10	12.5	12.5	68	4	10	1.400	2	219.00
9B-Q-10-GL14-S	Semi-Micro, Black Wall	10	12.5	12.5	68	4	10	1.400	2	315.00
18-Q-10-GL14-S	Septum Cap, Micro	10	12.5	12.5	68	2	10	0.700	2	269.00
18B-Q-10-GL14-S	Micro, Black Wall	10	12.5	12.5	68	2	10	0.700	2	359.00

Short Path Length, Demountable

The Type 20 cell is designed for use in applications where a short path length and large window surface area is needed. This cell design is especially useful for opaque or viscous solutions. The cell consists of one fully fused component combining one window and the sides of the cell which forms the path length. The other window is separate and the cell can therefore be taken apart for cleaning. The cell wall and the removable window are polished so flat that the two will form a seal when placed in contact. Viscous and aqueous samples will allow the best seal to be formed, organic solvents will creep into the seal area for a less reliable seal.

Type 20/O is open at one end similar to a Standard cell, unlike the Type 20/C which is completely enclosed when the window is in place. It is recommended that the cell holder Type CH-2049, shown below, is used with these cells to keep the cell together while standing in the instrument cell holder.

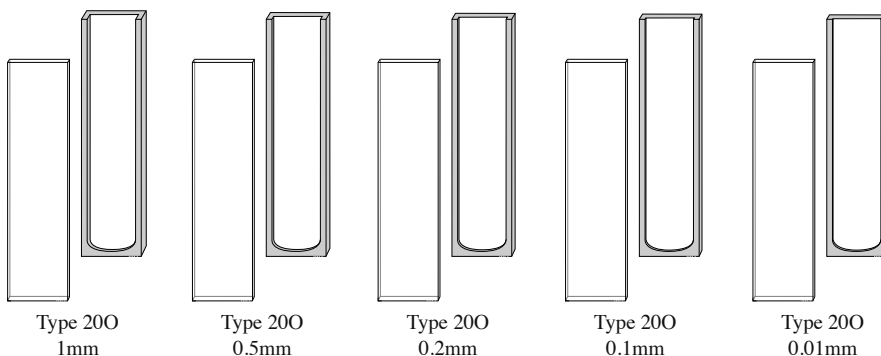
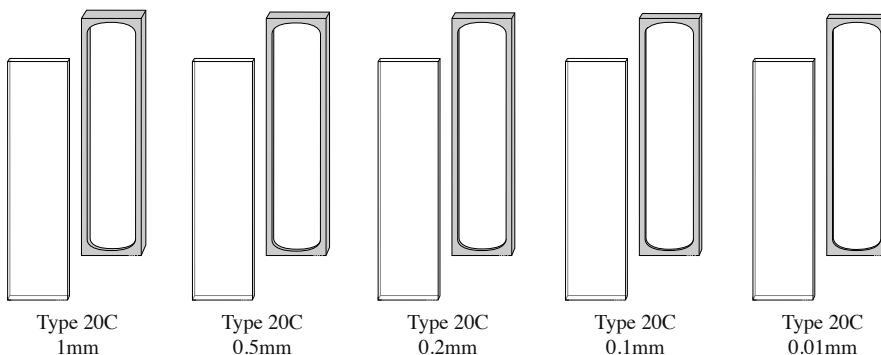

Cell Holder

This cell holder is designed to lightly clamp the type 20 cells in a vertical orientation for use in a standard instrument cell holder. Exterior dimensions are 12.5 x 12.5 x 52mm. The base is 9mm thick. This cell holder works with cells having a 2mm pathlength or less.



Cat. No	Description	Price, each
CH-2049	Cell holder	\$ 69.00

Catalog Number	Path Length mm	Exterior, mm			Sample Chamber, mm			Nominal Vol ml	Polished Windows	Price per cell
		Width	Length	Height	Width	Length	Height			
<i>Spectrosil® Far UV Quartz windows, Useable range: 170 to 2700 nm</i>										
20/O-Q-0.01	0.01	12.5	2.5	45	10	0.01	40	0.004	2	\$ 285.00
20/O-Q-0.1	0.1	12.5	2.6	45	10	0.1	40	0.040	2	165.00
20/O-Q-0.2	0.2	12.5	2.7	45	10	0.2	40	0.080	2	165.00
20/O-Q-0.5	0.5	12.5	3	45	10	0.5	40	0.190	2	165.00
20/O-Q-1	1	12.5	3.5	45	10	1	40	0.390	2	159.00
<i>Open Top</i>										
20/C-Q-0.01	0.01	12.5	2.5	45	8	0.01	40	0.003	2	\$ 285.00
20/C-Q-0.1	0.1	12.5	2.6	45	8	0.1	40	0.030	2	165.00
20/C-Q-0.2	0.2	12.5	2.7	45	8	0.2	40	0.060	2	165.00
20/C-Q-0.5	0.5	12.5	3	45	8	0.5	40	0.150	2	165.00
20/C-Q-1	1	12.5	3.5	45	8	1	40	0.310	2	159.00
<i>Closed Both Ends</i>										

Short Path Length, Flow Cells

Cell Types 48 and 49 are designed for use in various applications where a flow cell with a small path length and a large window surface area is needed. Flow tubes are fused to the front window of the cell, in the case of Type 49, the removable window. The cells will fit any spectrophotometer which can accommodate a normal cell with a 40mm path length. This allows introduction of the inlet/outlet tubes parallel to the light beam. The Type 48 is a fully fused cell.

The demountable cells Type 49, with removable window, must be held together when being used. Cell holder Type CH-2049, shown below, is designed for this purpose. These cells may be taken apart for easy cleaning. This cell design is especially useful for opaque or viscous solutions. The cell consists of one fully fused component combining one window and the sides of the cell which forms the path length. The other window is separate and the cell can therefore be taken apart for cleaning. The cell wall and the removable window are polished so flat that the two will form a seal when placed in contact. Viscous and aqueous samples will allow the best seal to be formed, organic solvents will creep into the seal area for a less reliable seal.

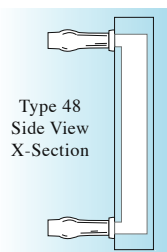

Type 48
Side View
X-Section

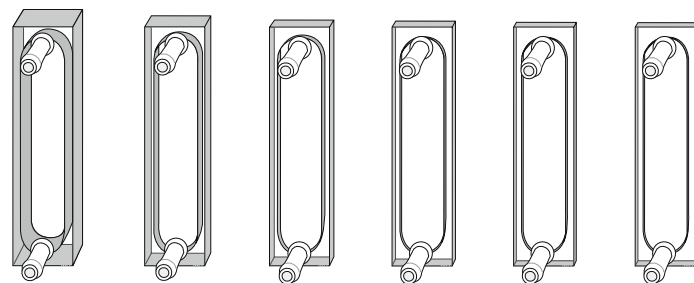

Type 48 5mm
Type 48 2mm
Type 48 1mm
Type 48 0.5mm
Type 48 0.2mm
Type 48 0.1mm

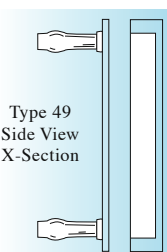

Type 49
Side View
X-Section

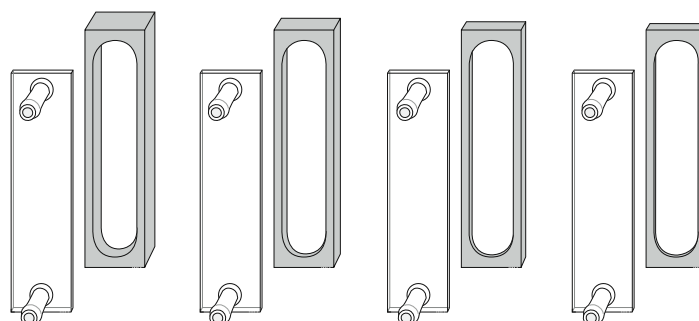

Type 49 5mm
Type 49 2mm
Type 49 1mm
Type 49 0.5mm

Cell Holder

This cell holder is designed to lightly clamp the type 20 cells in a vertical orientation for use in a standard instrument cell holder. Exterior dimensions are 12.5 x 12.5 x 52mm. The base is 9mm thick. This cell holder works with cells having a 2mm pathlength or less.



Cat. No	Description	Price, each
CH-2049	Cell holder	\$ 69.00

Flow cell Tubulation dimensions:

OD	ID	Length
4.2mm	2.0mm	16mm

Catalog Number	Path Length mm	Exterior, mm			Sample Chamber, mm			Volume in ml	Polished Windows	Price per cell
		Width	Length	Height	Width	Length	Height			
<i>Spectrosil® Far UV Quartz windows, Useable range: 170 to 2700 nm</i>										
48-Q-0.1	0.1	12.5	2.6	45	8	0.1	40	0.030	2	\$ 255.00
48-Q-0.2	0.2	12.5	2.7	45	8	0.2	40	0.060	2	255.00
48-Q-0.5	0.5	12.5	3	45	8	0.5	40	0.150	2	255.00
48-Q-1	1	12.5	3.5	45	8	1	40	0.300	2	245.00
48-Q-2	2	12.5	4.5	45	8	2	40	0.600	2	245.00
48-Q-5	5	12.5	7.5	45	8	5	40	1.560	2	245.00
<i>Spectrosil® Far UV Quartz windows, Useable range: 170 to 2700 nm</i>										
49-Q-0.1	0.1	12.5	2.6	45	8	0.1	40	0.030	2	\$ 255.00
49-Q-0.2	0.2	12.5	2.7	45	8	0.2	40	0.060	2	255.00
49-Q-0.5	0.5	12.5	3	45	8	0.5	40	0.150	2	255.00
49-Q-1	1	12.5	3.5	45	8	1	40	0.300	2	245.00
49-Q-2	2	12.5	4.5	45	8	2	40	0.600	2	245.00
49-Q-5	5	12.5	7.5	45	8	5	40	1.560	2	245.00

Flow Cells, Standard & Semi-Micro

Type 71 Standard, and 72 Semi-Micro series flow cells are suitable for use with instruments which have either 8.5 or 15 mm 'Z' dimensions, where the volume of the sample available is not a critical factor.

Type 46 Standard and 47 Semi-Micro are for in-line continuous flow type applications. Samples normally flow from the bottom to the top.

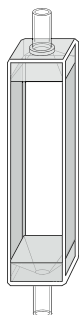

46-Q-10

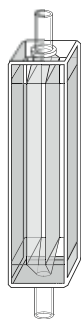

47-Q-10

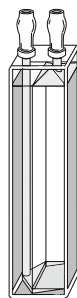

Type 71
10mm

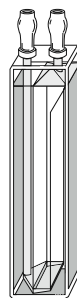

Type 72
10mm



Type 71B
10mm



Type 72B
10mm

Flow cell Tubulation dimensions:

OD	ID	Length
3.5mm	2.2mm	10mm

Catalog Number	Path Length mm	Exterior, mm			Sample Chamber, mm			'Z' Dim mm	Nominal Vol ml	Polished Windows	Price per cell
		Width	Length	Height	Width	Length	Height				

Spectrosil® Far UV Quartz windows, Useable range: 170 to 2700 nm Standard in-Line

46-Q-10	10	12.5	12.5	45	10	10	40	fits all	4.000	2	\$ 215.00
<i>Semi-Micro in-Line</i>											
47-Q-10	10	12.5	12.5	45	4	10	40	fits all	1.600	2	\$ 375.00

Catalog Number	Path Length mm	Exterior, mm			Sample Chamber, mm			'Z' Dim mm	Nominal Vol. ml	Polished Windows	Price per cell
		Width	Length	Height	Width	Length	Height				

Spectrosil® Far UV Quartz windows, Useable range: 170 to 2700 nm

71-Q-10	10	12.5	12.5	48	7	10	40	fits all	3.000	2	\$ 399.00
72-Q-10	10	12.5	12.5	48	4	10	40	fits all	1.800	2	399.00
<i>Black Walls, Self Masking</i>											
71B-Q-1	1	12.5	12.5	48	7	1	40	fits all	0.300	2	\$ 535.00
71B-Q-10	10	12.5	12.5	48	7	10	40	fits all	3.000	2	429.00
72B-Q-1	1	12.5	12.5	48	4	1	40	fits all	0.180	2	585.00
72B-Q-10	10	12.5	12.5	48	4	10	40	fits all	1.800	2	429.00

M6 Threaded Flow Cells

The fully fused Far UV quartz flow cell body mounted in a threaded anodized aluminum jacket. The aluminum exterior has internally threaded (M6 threading) inlet/outlet ports into which the PTFE flow tubes are connected. This allows for a tight seal between the inlet/outlet tubes and the flow cell body while making connections very easy to change. All cells and tubing connections are tested to 5 bar pressure (75 psi).

The exterior dimensions of the flow cells are made to international standards which should allow their use with commonly available commercial instruments. Almost any UV/Vis spectrophotometer has a cell holder which will work with the flow cells having a pathlength of 10mm or less. For pathlengths greater than 10mm consult your instrument handbook for the correct cell holder to use from your instrument manufacturer.

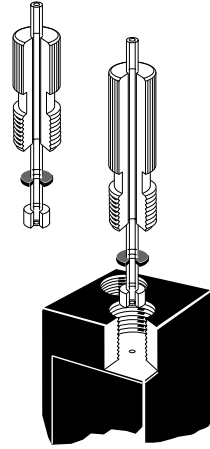

Cut away showing M6 threaded connectors

M6 Flow cell Tubulation dimensions:

OD: 1.6mm ID:1mm Length: 400mm

'Z' Dimension per Instrument

Manufacturer:	'Z' Dimension:
Agilent®	15 mm
Beckman®	8.5 mm
Bio-Rad®	8.5 mm
Eppendorf®	8.5 mm
GBC®	15 mm
Hewlett Packard®	15 mm
Hitachi®	varies by instrument
Jasco®	12 mm
Ocean Optics®	15 mm
Perkin-Elmer®	15 mm
Pharmacia®	15 mm
Shimadzu®	15 mm
StellarNet®	15 mm
Thermo Spectronic®	8.5 and 15 mm
Turner®	8.5 mm
Varian®	20 mm

Flow Cells, Medium Aperture

The Type 583.4 series of flow cells are designed to fit most spectrophotometers and are available in most 'Z' dimensions. They have a rectangular window in a black self masking configuration and are widely used for many standard applications including Tablet dissolution. The sample chamber width is 4mm and is available with path lengths of 5, 10, 20, 40, 50, and 100mm. The inlet and outlet tubes are connected into the flow cell with a M6 threaded connector. The PTFE tubing has an outer diameter of about 1.6mm and an inner diameter of about 1mm. The length of the tubing is approximately 400mm. Each cell is supplied with an inlet and an outlet tube. Extra tubing sets may be purchased.

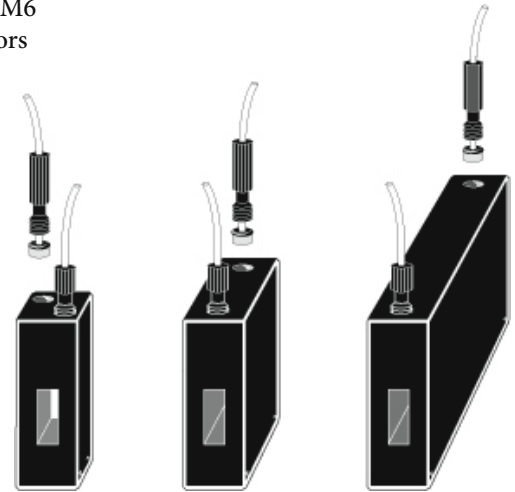

Catalog Number	Path Length mm	Exterior, mm			Sample Chamber, mm			'Z' Dim mm	Nominal Vol. ml	Polished Windows	Price per cell
		Width	Length	Height	Width	Length	Height				
<i>Spectrosil® Far UV Quartz window, Useable range: 170 to 2700 nm</i>											
583.4-Q-5/Z8.5	5	12.5	12.5	35	4	5	11	8.5	0.225	2	\$ 499.00
583.4-Q-10/Z8.5	10	12.5	12.5	35	4	10	11	8.5	0.450	2	375.00
583.4-Q-20/Z8.5	20	12.5	12.5	35	4	20	11	8.5	0.900	2	645.00
583.4-Q-40/Z8.5	40	12.5	12.5	35	4	40	11	8.5	1.800	2	779.00
583.4-Q-50/Z8.5	50	12.5	12.5	35	4	50	11	8.5	2.250	2	895.00
583.4-Q-100/Z8.5	100	12.5	12.5	35	4	100	11	8.5	4.500	2	1,309.00
583.4-Q-5/Z15	5	12.5	12.5	35	4	5	11	15	0.225	2	\$ 499.00
583.4-Q-10/Z15	10	12.5	12.5	35	4	10	11	15	0.450	2	375.00
583.4-Q-20/Z15	20	12.5	12.5	35	4	20	11	15	0.900	2	645.00
583.4-Q-40/Z15	40	12.5	12.5	35	4	40	11	15	1.800	2	779.00
583.4-Q-50/Z15	50	12.5	12.5	35	4	50	11	15	2.250	2	895.00
583.4-Q-100/Z15	100	12.5	12.5	35	4	100	11	15	4.500	2	1,309.00
583.4-Q-5/Z20	5	12.5	12.5	35	4	5	11	20	0.225	2	499.00
583.4-Q-10/Z20	10	12.5	12.5	35	4	10	11	20	0.450	2	375.00
583.4-Q-20/Z20	20	12.5	12.5	35	4	20	11	20	0.900	2	645.00
583.4-Q-40/Z20	40	12.5	12.5	35	4	40	11	20	1.800	2	779.00
583.4-Q-50/Z20	50	12.5	12.5	35	4	50	11	20	2.250	2	895.00
583.4-Q-100/Z20	100	12.5	12.5	35	4	100	11	20	4.500	2	1,309.00
M6-SET		Set of extra inlet/outlet tubes with M6 connectors (two tubes per set)									\$ 69.00

Flow Cells, Wide Aperture

The Type 583.65 series of flow cells have a wide aperture (6.5mm) that are optimized for instruments with a wide light beam. They have a rectangular window in a black self masking configuration and are widely used for many standard applications including Tablet dissolution. The sample chamber width of 6.5mm is available with path lengths of 0.1, 0.2, 0.5, 1, 2, 5, 10, 20, 40, 50, and 100mm. The inlet and outlet tubes are connected into the flow cell with a M6 threaded connector. The PTFE tubing has an outer diameter of about 1.6mm and an inner diameter of about 1mm. The length of the tubing is approximately 400mm. Each cell is supplied with an inlet and an outlet tube. Extra tubing sets may be purchased.

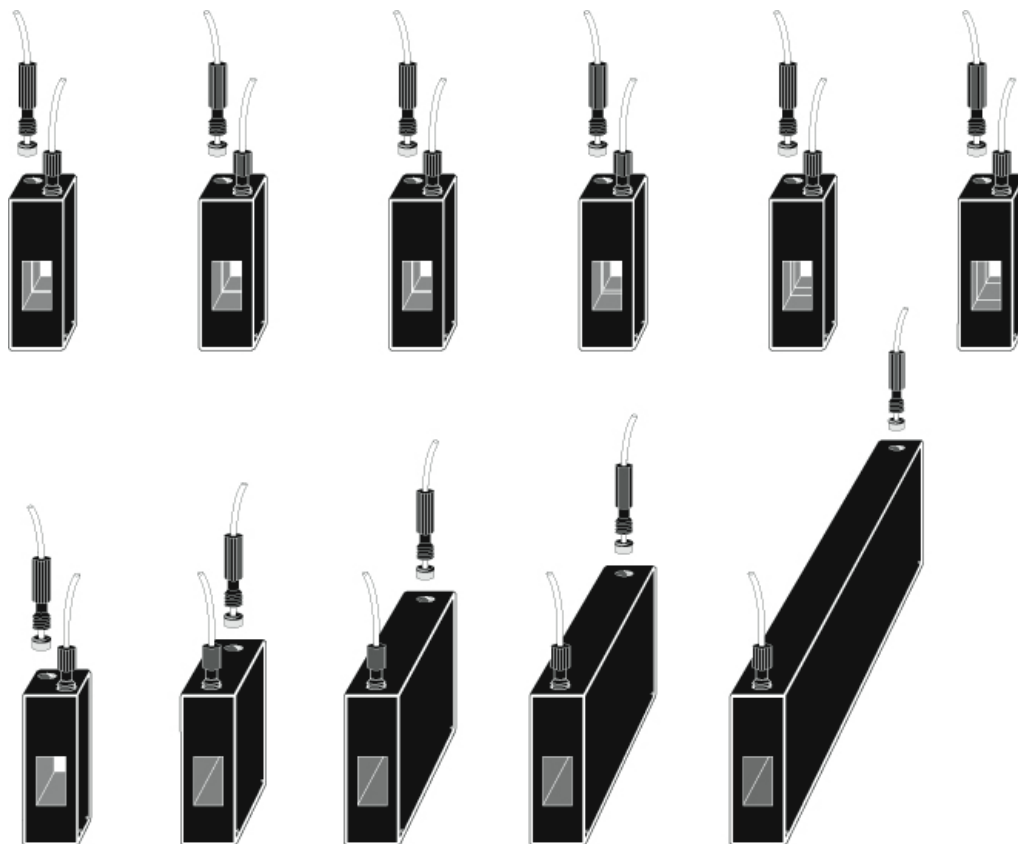

Catalog Number	Path Length mm	Exterior, mm			Sample Chamber, mm			'Z' Dim mm	Nominal Vol. ml	Polished Windows	Price per cell
		Width	Length	Height	Width	Length	Height				
<i>Spectrosil® Far UV Quartz window, Useable range: 170 to 2700 nm</i>											
583.65-Q-0.1/Z15	0.1	12.5	12.5	35	6.5	0.1	11	15	0.029	2	\$ 715.00
583.65-Q-0.2/Z15	0.2	12.5	12.5	35	6.5	0.2	11	15	0.036	2	715.00
583.65-Q-0.5/Z15	0.5	12.5	12.5	35	6.5	0.5	11	15	0.072	2	669.00
583.65-Q-1/Z15	1	12.5	12.5	35	6.5	1	11	15	0.072	2	519.00
583.65-Q-2/Z15	2	12.5	12.5	35	6.5	2	11	15	0.290	2	509.00
583.65-Q-5/Z15	5	12.5	12.5	35	6.5	5	11	15	0.360	2	459.00
583.65-Q-10/Z15	10	12.5	12.5	35	6.5	10	11	15	0.420	2	389.00
583.65-Q-20/Z15	20	12.5	22.5	35	6.5	20	11	15	1.400	2	589.00
583.65-Q-40/Z15	40	12.5	42.5	35	6.5	40	11	15	2.900	2	789.00
583.65-Q-50/Z15	50	12.5	52.5	35	6.5	50	11	15	3.600	2	909.00
583.65-Q-100/Z15	100	12.5	102.5	35	6.5	100	11	15	7.200	2	1,219.00

583.65-Q-0.1/Z20	0.1	12.5	12.5	40	6.5	0.1	11	20	0.029	2	\$ 715.00
583.65-Q-0.2/Z20	0.2	12.5	12.5	40	6.5	0.2	11	20	0.036	2	715.00
583.65-Q-0.5/Z20	0.5	12.5	12.5	40	6.5	0.5	11	20	0.072	2	669.00
583.65-Q-1/Z20	1	12.5	12.5	40	6.5	1	11	20	0.072	2	519.00
583.65-Q-2/Z20	2	12.5	12.5	40	6.5	2	11	20	0.290	2	509.00
583.65-Q-5/Z20	5	12.5	12.5	40	6.5	5	11	20	0.360	2	459.00
583.65-Q-10/Z20	10	12.5	12.5	40	6.5	10	11	20	0.420	2	389.00
583.65-Q-20/Z20	20	12.5	22.5	40	6.5	20	11	20	1.400	2	589.00
583.65-Q-40/Z20	40	12.5	42.5	40	6.5	40	11	20	2.900	2	789.00
583.65-Q-50/Z20	50	12.5	52.5	40	6.5	50	11	20	3.600	2	909.00
583.65-Q-100/Z20	100	12.5	102.5	40	6.5	100	11	20	7.200	2	1,219.00

M6-SET Set of extra inlet/outlet tubes with M6 connectors (two tubes per set) \$ 69.00

Flow Cells, Wide Aperture, short window

The Type 583.65.65 series of flow cells have a wide aperture (6.5mm) and a smaller sample size. They have a rectangular window in a black self masking configuration and are widely used for many standard applications including Tablet dissolution. The sample chamber width of 6.5mm is available with path lengths of 1, 2, 5, 10mm. The inlet and outlet tubes are connected into the flow cell with a M6 threaded connector. The PTFE tubing has an outer diameter of about 1.6mm and an inner diameter of about 1mm. The length of the tubing is approximately 400mm. Each cell is supplied with an inlet and an outlet tube. Extra tubing sets may be purchased.



Catalog Number	Path Length mm	Exterior, mm			Sample Chamber, mm			'Z' Dim mm	Nominal Vol. ml	Polished Windows	Price per cell
		Width	Length	Height	Width	Length	Height				
<i>Spectrosil® Far UV Quartz window, Useable range: 170 to 2700 nm</i>											
583.65.65-Q-1/Z15	1	12.5	12.5	35	6.5	1	6.5	15	0.042	2	\$ 519.00
583.65.65-Q-2/Z15	2	12.5	12.5	35	6.5	2	6.5	15	0.084	2	509.00
583.65.65-Q-5/Z15	5	12.5	12.5	35	6.5	5	6.5	15	0.210	2	459.00
583.65.65-Q-10/Z15	10	12.5	12.5	35	6.5	10	6.5	15	0.420	2	389.00
583.65.65-Q-1/Z20	1	12.5	12.5	40	6.5	1	6.5	20	0.042	2	\$ 519.00
583.65.65-Q-2/Z20	2	12.5	12.5	40	6.5	2	6.5	20	0.084	2	509.00
583.65.65-Q-5/Z20	5	12.5	12.5	40	6.5	5	6.5	20	0.210	2	459.00
583.65.65-Q-10/Z20	10	12.5	12.5	40	6.5	10	6.5	20	0.420	2	389.00
M6-SET	Set of extra inlet/outlet tubes with M6 connectors (two tubes per set)										\$ 69.00

Flow Cells, Short Path Length

This series of flow cell is typified by a tall sample compartment with a window height of 17.5mm for use in both 8.5 and 15mm 'Z' dimension situations. Path lengths as short as 0.01mm are available in this range. Smooth flow characteristics at very short path lengths are achieved with a bypass facility at each side of the window which also avoids increased pressure in the cell and helps to minimize air bubbles. The width of the sample chamber is 4mm. The PTFE inlet and outlet tubes are connected into the flow cell with a M6 threaded connector. The tubing has an outer diameter of about 1.6mm and an inner diameter of about 1mm. The length of the tubing is approximately 400mm. Each cell is supplied with an inlet and an outlet tube. Extra tubing sets may be purchased.



Catalog Number	Path Length mm	Exterior, mm			Sample Chamber, mm			'Z' Dim mm	Nominal Vol. ml	Polished Windows	Price per cell
		Width	Length	Height	Width	Length	Height				
<i>Spectrosil® Far UV Quartz window, Useable range: 170 to 2700 nm</i>											
584.4-Q-0.01	0.01	12.5	12.5	35	4	0.01	17.5	8.5 & 15	0.036	2	\$ 755.00
584.4-Q-0.05	0.05	12.5	12.5	35	4	0.05	17.5	8.5 & 15	0.039	2	715.00
584.4-Q-0.1	0.1	12.5	12.5	35	4	0.1	17.5	8.5 & 15	0.041	2	645.00
584.4-Q-0.2	0.2	12.5	12.5	35	4	0.2	17.5	8.5 & 15	0.047	2	645.00
584.4-Q-0.5	0.5	12.5	12.5	35	4	0.5	17.5	8.5 & 15	0.095	2	645.00
584.4-Q-1	1	12.5	12.5	35	4	1	17.5	8.5 & 15	0.120	2	505.00
584.4-Q-2	2	12.5	12.5	35	4	2	17.5	8.5 & 15	0.240	2	505.00
M6-SET	Set of extra inlet/outlet tubes with M6 connectors (two tubes per set)										\$ 69.00

Flow Cells, Ultra-micro, round aperture

Type 585.1 and 585.15 are designed to optimize a very small sample volume by using a cylindrical sample chamber with a very small diameter. The diameter of the aperture on the 585.1 series of flow cells is 1 mm and the aperture on the 585.15 series is 1.5mm. The choice of the correct 'Z' dimension for your instrument is critical as you must ensure that the light beam of the instrument passes through the sample chamber of the cell. The cell is designed with a threaded jacket which will accept M6 threaded connectors. Available 'Z' Dimensions are 8.5, 15 (cell height 35mm) and 20mm (cell height 40mm).

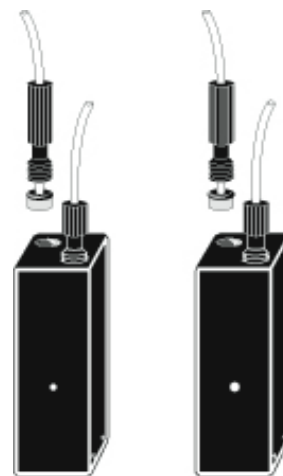

Catalog Number	Path Length mm	Exterior, mm		Sample Chamber, mm		'Z' Dim mm	Nominal Vol. ml	Polished Windows	Price per cell	
		Width	Length	Height	Diameter Ø					
<i>Special Optical Glass windows, Useable range: 320 to 2500 nm</i>									<i>M6 Threaded Jacket</i>	
585.1-SOG-10/Z8.5	10	12.5	12.5	35	1	10	8.5	0.008	2	\$ 325.00
585.15-SOG-10/Z8.5	10	12.5	12.5	35	1.5	10	8.5	0.018	2	325.00
585.1-SOG-10/Z15	10	12.5	12.5	35	1	10	15	0.008	2	325.00
585.15-SOG-10/Z15	10	12.5	12.5	35	1.5	10	15	0.018	2	325.00
585.1-SOG-10/Z20	10	12.5	12.5	40	1	10	20	0.008	2	325.00
585.15-SOG-10/Z20	10	12.5	12.5	40	1.5	10	20	0.018	2	325.00
<i>Spectrosil® Far UV Quartz windows, Useable range: 170 to 2700 nm</i>									<i>M6 Threaded Jacket</i>	
585.1-Q-10/Z8.5	10	12.5	12.5	35	1	10	8.5	0.008	2	\$ 425.00
585.15-Q-10/Z8.5	10	12.5	12.5	35	1.5	10	8.5	0.008	2	425.00
585.1-Q-10/Z15	10	12.5	12.5	35	1	10	15	0.008	2	425.00
585.15-Q-10/Z15	10	12.5	12.5	35	1.5	10	15	0.008	2	425.00
585.1-Q-10/Z20	10	12.5	12.5	40	1	10	20	0.008	2	425.00
585.15-Q-10/Z20	10	12.5	12.5	40	1.5	10	20	0.008	2	425.00

Flow Cells, Sub-micro, round aperture

Type 585.2 is designed to optimize a small sample volume by using a cylindrical sample chamber with a small diameter. The diameter of the aperture on the 585.2 series of flow cells is 2 mm. The choice of the correct 'Z' dimension for your instrument is critical as you must ensure that the light beam of the instrument passes through the sample chamber of the cell. The cell is designed with a threaded jacket which will accept M6 threaded connectors. Available 'Z' Dimensions are 8.5, 15 (cell height 35mm) and 20mm (cell height 40mm).



Catalog Number	Path Length mm	Exterior, mm		Sample Chamber, mm		'Z' Dim mm	Nominal Vol. ml	Polished Windows	Price per cell	
		Width	Length	Height	Diameter Ø					
<i>Special Optical Glass windows, Useable range: 320 to 2500 nm</i>									<i>M6 Threaded Jacket</i>	
585.2-SOG-10/Z8.5	10	12.5	12.5	35	2	10	8.5	0.032	2	\$ 299.00
585.2-SOG-10/Z15	10	12.5	12.5	35	2	10	15	0.032	2	299.00
585.2-SOG-10/Z20	10	12.5	12.5	40	2	10	20	0.032	2	299.00
<i>Spectrosil® Far UV Quartz windows, Useable range: 170 to 2700 nm</i>									<i>M6 Threaded Jacket</i>	
585.2-Q-10/Z8.5	10	12.5	12.5	35	2	10	8.5	0.032	2	\$ 385.00
585.2-Q-10/Z15	10	12.5	12.5	35	2	10	15	0.032	2	385.00
585.2-Q-10/Z20	10	12.5	12.5	40	2	10	20	0.032	2	385.00

Flow Cells, Round Aperture

Type 585.3 is designed to optimize a small sample volume by using a cylindrical sample chamber with a small diameter. The diameter of the aperture on the 585.3 series of flow cells is 3mm. The choice of the correct 'Z' dimension for your instrument is critical as you must ensure that the light beam of the instrument passes through the sample chamber of the cell. The cell is designed with a threaded jacket which will accept M6 threaded connectors. Available 'Z' Dimensions are 8.5, 15 (cell height 35mm) and 20mm (cell height 40mm).

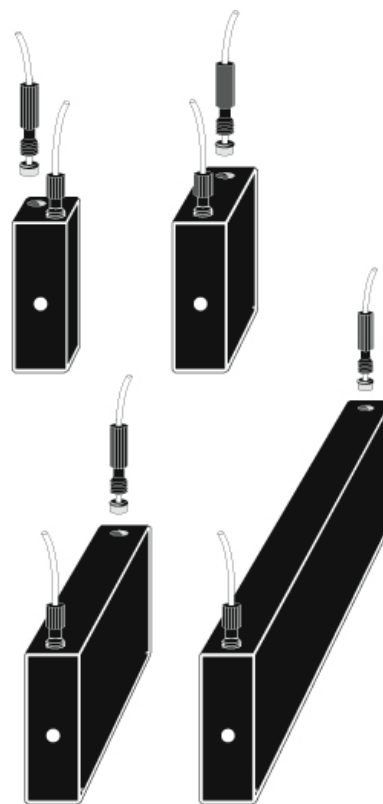

'Z' Dimension per Instrument

Manufacturer:	'Z' Dimension:
Agilent®	15 mm
Beckman®	8.5 mm
Bio-Rad®	8.5 mm
Eppendorf®	8.5 mm
GBC®	15 mm
Hewlett Packard®	15 mm
Hitachi®	varies by instrument
Jasco®	12 mm
Ocean Optics®	15 mm
Perkin-Elmer®	15 mm
Pharmacia®	15 mm
Shimadzu®	15 mm
StellarNet®	15 mm
Thermo Spectronic®	8.5 and 15 mm
Turner®	8.5 mm
Varian®	20 mm

Catalog Number	Path Length mm	Exterior, mm			Sample Chamber, mm		'Z' Dim mm	Nominal Vol. ml	Polished Windows	Price per cell
		Width	Length	Height	Diameter Ø	Length				
<i>Special Optical Glass windows, Useable range: 320 to 2500 nm</i>										
<i>M6 Threaded Jacket</i>										
585.3-SOG-10/Z15	10	12.5	12.5	35	3	10	15	0.070	2	\$ 285.00
585.3-SOG-20/Z15	20	12.5	12.5	35	3	20	15	0.140	2	445.00
585.3-SOG-40/Z15	40	12.5	12.5	35	3	40	15	0.280	2	665.00
585.3-SOG-50/Z15	50	12.5	12.5	35	3	50	15	0.350	2	805.00
585.3-SOG-100/Z15	100	12.5	12.5	35	3	100	15	0.700	2	1,309.00
(Z=8.5mm and Z=20mm also available)										
<i>Spectrosil® Far UV Quartz windows, Useable range: 170 to 2700 nm</i>										
<i>M6 Threaded Jacket</i>										
585.3-Q-10/Z8.5	10	12.5	12.5	35	3	10	8.5	0.070	2	\$ 349.00
585.3-Q-20/Z8.5	20	12.5	12.5	35	3	20	8.5	0.140	2	479.00
585.3-Q-40/Z8.5	40	12.5	12.5	35	3	40	8.5	0.280	2	769.00
585.3-Q-50/Z8.5	50	12.5	12.5	35	3	50	8.5	0.350	2	869.00
585.3-Q-100/Z8.5	100	12.5	12.5	35	3	100	8.5	0.700	2	1,309.00
585.3-Q-10/Z15	10	12.5	12.5	35	3	10	15	0.070	2	\$ 349.00
585.3-Q-20/Z15	20	12.5	12.5	35	3	20	15	0.140	2	479.00
585.3-Q-40/Z15	40	12.5	12.5	35	3	40	15	0.280	2	769.00
585.3-Q-50/Z15	50	12.5	12.5	35	3	50	15	0.350	2	869.00
585.3-Q-100/Z15	100	12.5	12.5	35	3	100	15	0.700	2	1,309.00
585.3-Q-10/Z20	10	12.5	12.5	40	3	10	20	0.070	2	\$ 349.00
585.3-Q-20/Z20	20	12.5	12.5	40	3	20	20	0.140	2	479.00
585.3-Q-40/Z20	40	12.5	12.5	40	3	40	20	0.280	2	769.00
585.3-Q-50/Z20	50	12.5	12.5	40	3	50	20	0.350	2	869.00
585.3-Q-100/Z20	100	12.5	12.5	40	3	100	20	0.700	2	1,309.00

Cylindrical Cells

The Type 31 range has path lengths 0.01mm to 5mm, with a sample compartment aperture of 15mm. Please note when filling cylindrical cells, to avoid damage to the windows, do not fill cell to the top. Leave an air gap otherwise the windows will be broken by the hydraulic pressure of the stopper being inserted. A PTFE stopper is supplied with the cell.

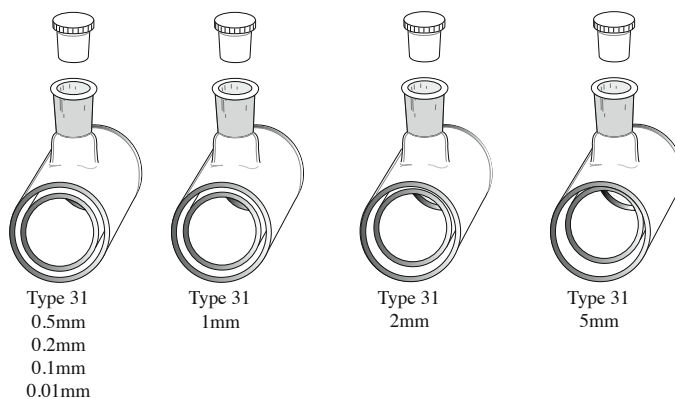

INTERNAL CROSS SECTION

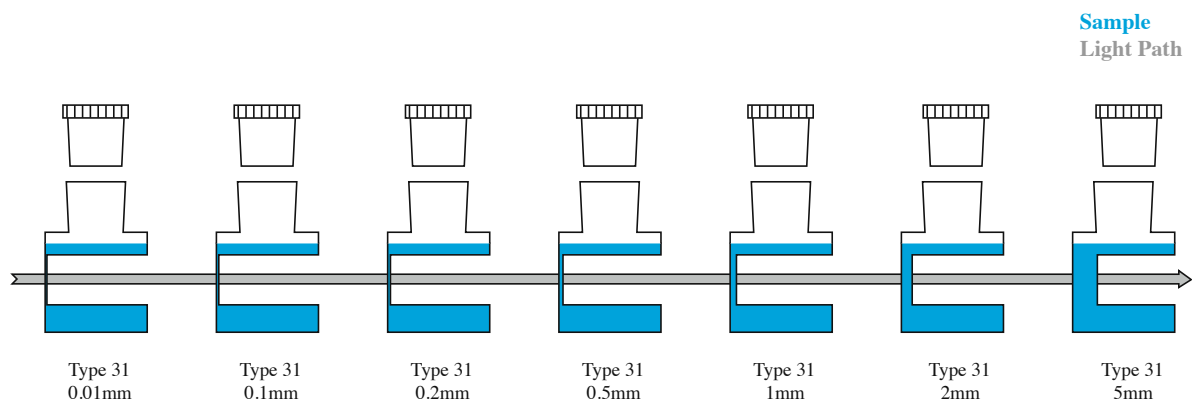

Catalog Number	Path Length mm	Exterior, mm Diameter	Exterior, mm Length	Interior, mm Width	Interior, mm Length	Nominal Vol. ml	Number of Stoppers	Polished Windows	Price per cell
<i>Spectrosil® Far UV Quartz windows, Useable range: 170 to 2700 nm</i>									
31-Q-0.01	0.01	22	22.5	15	0.01	2.150	1	2	\$ 475.00
31-Q-0.1	0.10	22	22.5	15	0.1	2.150	1	2	319.00
31-Q-0.2	0.20	22	22.5	15	0.2	2.180	1	2	319.00
31-Q-0.5	0.50	22	22.5	15	0.5	2.220	1	2	319.00
31-Q-1	1	22	22.5	15	1	2.310	1	2	319.00
31-Q-2	2	22	22.5	15	2	2.490	1	2	285.00
31-Q-5	5	22	22.5	15	5	3.020	1	2	259.00
<i>Infrasil® or equivalent Near Infrared Quartz windows, Useable range: 220 to 3800 nm</i>									
31-I-0.01	0.01	22	22.5	15	0.01	2.150	1	2	\$ 499.00
31-I-0.1	0.10	22	22.5	15	0.1	2.150	1	2	335.00
31-I-0.2	0.20	22	22.5	15	0.2	2.180	1	2	335.00
31-I-0.5	0.50	22	22.5	15	0.5	2.220	1	2	335.00
31-I-1	1	22	22.5	15	1	2.310	1	2	335.00
31-I-2	2	22	22.5	15	2	2.490	1	2	299.00
31-I-5	5	22	22.5	15	5	3.020	1	2	269.00

Cylindrical Cells

The Type 31B range has path lengths 0.01mm to 5mm, with a sample compartment aperture of 13mm. The structure of this cylindrical cell allows for lower volume usage as compared to the requirements of the Type 31 cells.

Please note when filling cylindrical cells, to avoid damage to the windows, do not fill cell to the top. Leave an air gap otherwise the windows will be broken by the hydraulic pressure of the stopper being inserted. PTFE stoppers are supplied with these cells as shown in drawing below.

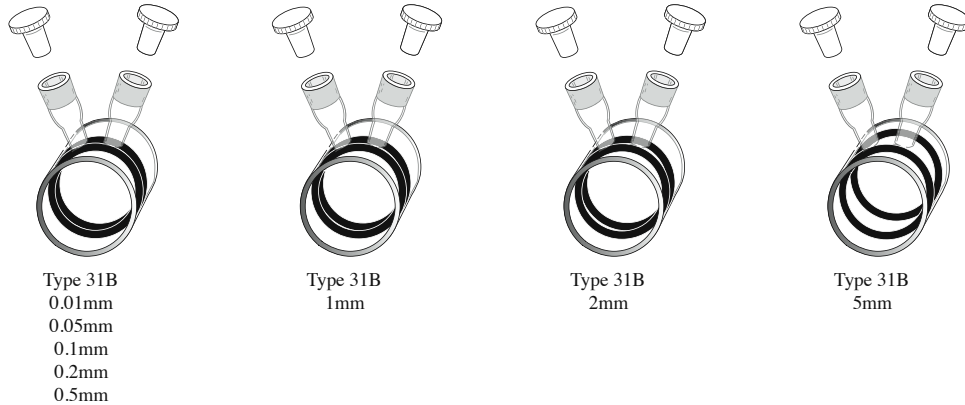

INTERNAL CROSS SECTION

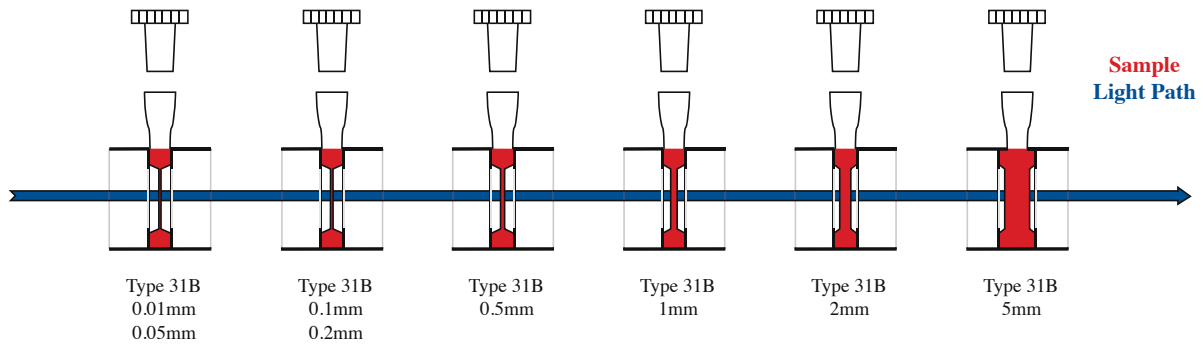

Catalog Number	Path Length mm	Exterior, mm Diameter	Exterior, mm Length	Interior, mm Width	Interior, mm Length	Nominal Vol. ml	Number of Stoppers	Polished Windows	Price per cell
<i>Spectrosil® Far UV Quartz windows, Useable range: 170 to 2700 nm</i>									
31B-Q-0.01	0.01	22	22.5	13	0.01	0.140	2	2	\$ 485.00
31B-Q-0.05	0.05	22	22.5	13	0.05	0.151	2	2	479.00
31B-Q-0.1	0.1	22	22.5	13	0.1	0.165	2	2	349.00
31B-Q-0.2	0.2	22	22.5	13	0.2	0.194	2	2	349.00
31B-Q-0.5	0.5	22	22.5	13	0.5	0.278	2	2	349.00
31B-Q-1	1	22	22.5	13	1	0.420	2	2	349.00
31B-Q-2	2	22	22.5	13	2	0.703	2	2	295.00
31B-Q-5	5	22	22.5	13	5	1.552	2	2	269.00

Cylindrical Cells

Type 32 and 34 cells range from path lengths of 10mm to 100mm with an internal diameter of 19mm. Other diameters available from 5mm ID to 30mm ID on request. Please note when filling cylindrical cells, to avoid damage to the windows, do not fill cell to the top. Leave an air gap otherwise the windows will be broken by the hydraulic pressure of the stopper being inserted. PTFE stoppers are supplied with each cell as pictured.

Adaptor for IR instruments

These adaptors will allow the use of 10 through 100mm cylindrical cells with Infrared instruments. All come complete with a 3" x 2" back plate to fit standard Infrared instrument holders. The adaptors are constructed of black anodized aluminum.

Cat. No	Description	Price, each
CH-32/25	Cylindrical 10 to 20mm	75.00
CH-34/100	Cylindrical 50 to 100mm	85.00

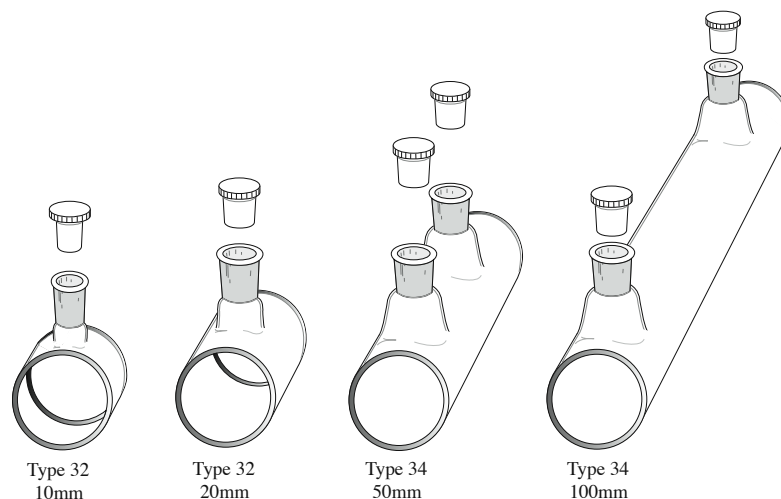

Catalog Number	Path Length mm	Exterior, mm Diameter	Exterior, mm Length	Interior, mm Width	Interior, mm Length	Nominal Vol. ml	Number of Stoppers	Polished Windows	Price per cell
<i>Special Optical Glass windows, Useable range: 320 to 2500 nm</i>									
32-SOG-10	10	22	12.5	19	10	2.800	1	2	\$ 89.00
32-SOG-20	20	22	22.5	19	20	5.600	1	2	95.00
34-SOG-50	50	22	52.5	19	50	14.100	2	2	105.00
34-SOG-100	100	22	102.5	19	100	28.200	2	2	109.00
<i>Spectrosil® Far UV Quartz windows, Useable range: 170 to 2700 nm</i>									
32-Q-10	10	22	12.5	19	10	2.800	1	2	\$ 119.00
32-Q-20	20	22	22.5	19	20	5.600	1	2	129.00
34-Q-50	50	22	52.5	19	50	14.100	2	2	169.00
34-Q-100	100	22	102.5	19	100	28.200	2	2	189.00
<i>Infrasil® or equivalent Near Infrared Quartz windows, Useable range: 220 to 3800 nm</i>									
32-I-10	10	22	12.5	19	10	2.800	1	2	\$ 135.00
32-I-20	20	22	22.5	19	20	5.600	1	2	145.00
34-I-50	50	22	52.5	19	50	14.100	2	2	185.00
34-I-100	100	22	102.5	19	100	28.200	2	2	199.00

Cylindrical Cells

Type 35 cells have a large aperture for use where a large surface irradiation area is required in either short or long path lengths. A PTFE stopper is supplied with the type 35 cells.

Note: Liquids do not compress like gases and therefore excessive pressure applied to the stopper of an overfilled cell will cause damage to the cell.

Although a tube can be attached to virtually any cell, the Type 37 design already incorporates a tube so that the cell can be attached to other apparatus, or sealed off with a flame, depending on the application. The tube can also be specified as a quartz to pyrex graded seal. Where this is required, call us for a quotation.

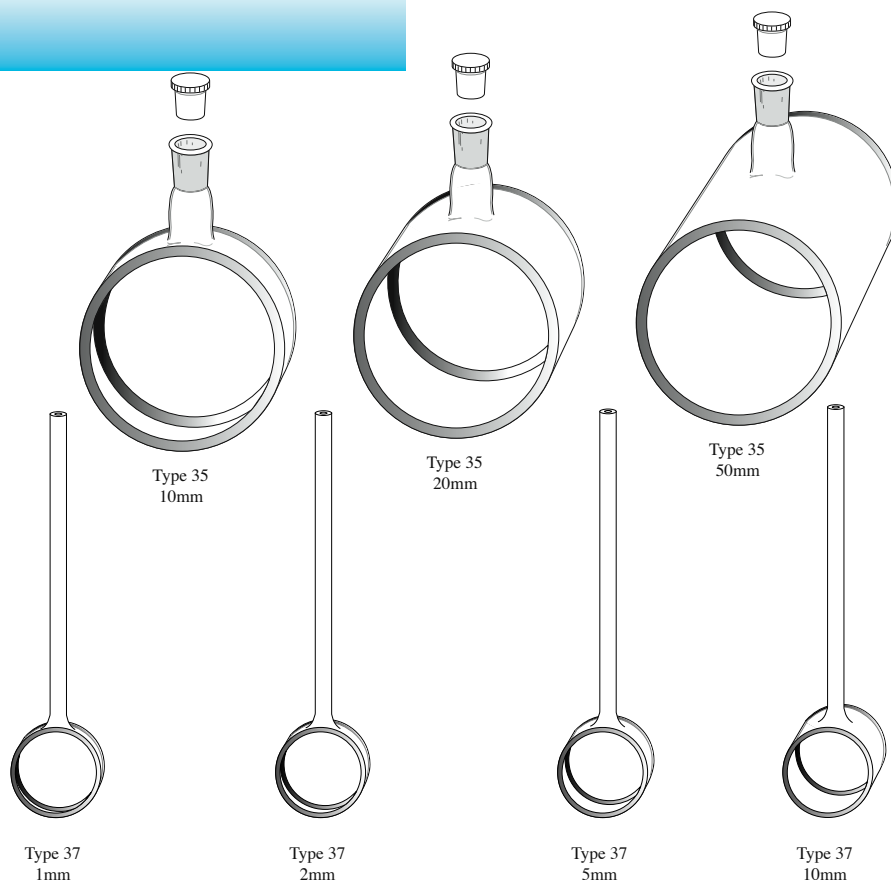

Catalog Number	Path Length mm	Exterior, mm		Interior, mm		Nominal Vol. ml	Number of Stoppers	Polished Windows	Price per cell
		Diameter	Length	Diameter	Length				
<i>Optical Pyrex windows, Useable range: 320 to 2500 nm</i>									
35-PX-10	10	50	12.5	47	10	17.00	1	2	\$ 149.00
35-PX-20	20	50	22.5	47	20	35.00	1	2	159.00
35-PX-50	50	50	52.5	47	50	86.00	1	2	175.00
<i>Spectrosil® Far UV Quartz windows, Useable range: 170 to 2700 nm</i>									
35-Q-10	10	50	12.5	47	10	17.00	1	2	\$ 305.00
35-Q-20	20	50	22.5	47	20	35.00	1	2	365.00
35-Q-50	50	50	52.5	47	50	86.00	1	2	415.00
<i>Optical Pyrex windows, Useable range: 320 to 2500 nm</i>									
37-PX-1	1	22	3.5	19	1	0.28	70	2	\$ 95.00
37-PX-2	2	22	4.5	19	2	0.56	70	2	95.00
37-PX-5	5	22	7.5	19	5	1.40	70	2	95.00
37-PX-10	10	22	12.5	19	10	2.80	70	2	95.00
<i>Spectrosil® Far UV Quartz windows, Useable range: 170 to 2700 nm</i>									
37-Q-1	1	22	3.5	19	1	0.28	70	2	\$ 169.00
37-Q-2	2	22	4.5	19	2	0.56	70	2	169.00
37-Q-5	5	22	7.5	19	5	1.40	70	2	165.00
37-Q-10	10	22	12.5	19	10	2.80	70	2	165.00
<i>Infrasil® or equivalent Near Infrared Quartz windows, Useable range: 220 to 3800 nm</i>									
37-I-1	1	22	3.5	19	1	0.28	70	2	\$ 179.00
37-I-2	2	22	4.5	19	2	0.56	70	2	179.00
37-I-5	5	22	7.5	19	5	1.40	70	2	179.00
37-I-10	10	22	12.5	19	10	2.80	70	2	175.00

Fluorometer Cells, Standard, Semi-Micro, Micro

Standard rectangular fluorometer cells Type 3 are the most popular cells for general fluorescence measurement and they will fit virtually every fluorometer instrument. All four windows and the bottom of the cell are polished and because of the technique used in their construction they remain extremely flat, right to the very edge of the window, allowing them to be used in some laser applications. Each cell is supplied with a PTFE cover.

Smaller volume Types 9F, 17F & 18F are identical to the Type 9 Semi-Micro, Type 17 Short-Micro and Type 18 Micro range, except that all cell walls and the base are optically polished.

Some applications require Anti-reflection coatings or Mirror coatings to be applied to two adjacent exterior walls to increase the sensitivity and enhance the energy received by the detector. To add the coatings to a cell use the suffix /AR for Anti reflection and /MC for Mirror coating (e.g. 3-Q-10/AR/MC for both coatings each on two adjacent faces). For prices see page 39.

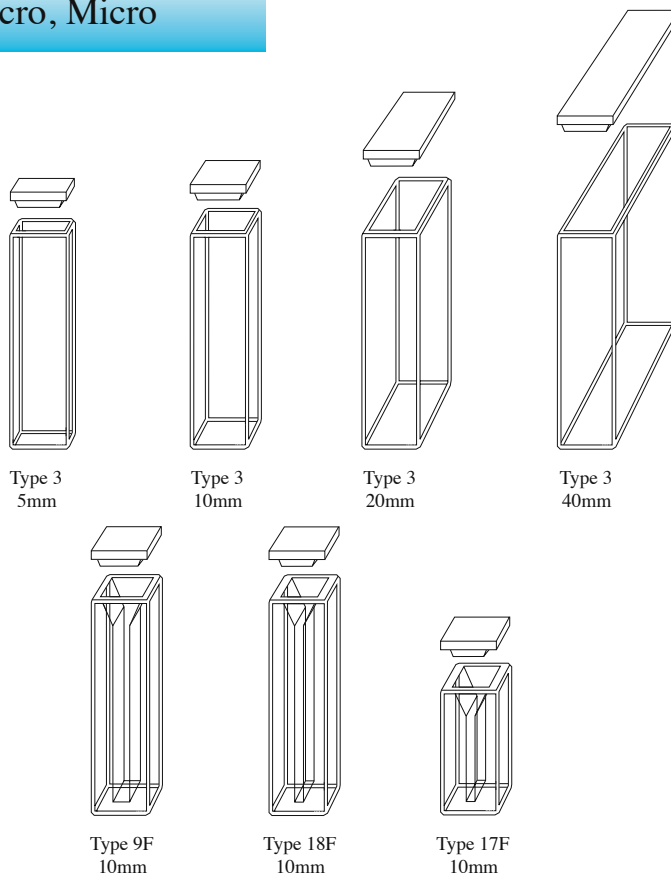

Catalog Number	Path Length mm	Exterior, mm			Interior, mm		Nominal Vol. ml	Polished		Price per cell
		Width	Length	Height	Width	Length		Windows	Base	
<i>Optical Glass windows, Useable range: 334 to 2500 nm</i>										
3-G-5	5	12.5	7.5	45	10	5	1.700	4	1	\$ 75.00
3-G-10	10	12.5	12.5	45	10	10	3.500	4	1	69.00
3-G-20	20	12.5	22.5	45	10	20	7.000	4	1	109.00
3-G-40	40	12.5	42.5	45	10	40	14.00	4	1	139.00
<i>Special Optical Glass windows, Useable range: 320 to 2500 nm</i>										
3-SOG-10	10	12.5	12.5	45	10	10	3.500	4	1	\$ 95.00
<i>Spectrosil® Far UV Quartz windows, Useable range: 170 to 2700 nm</i>										
3-Q-5	5	12.5	7.5	45	10	5	1.700	4	1	\$ 165.00
3-Q-10	10	12.5	12.5	45	10	10	3.500	4	1	129.00
3-Q-20	20	12.5	22.5	45	10	20	7.000	4	1	195.00
3-Q-40	40	12.5	42.5	45	10	40	14.00	4	1	229.00
<i>Infrasil® or equivalent Near Infrared Quartz windows, Useable range: 220 to 3800 nm</i>										
3-I-5	5	12.5	7.5	45	10	5	1.700	4	1	\$ 175.00
3-I-10	10	12.5	12.5	45	10	10	3.500	4	1	169.00
3-I-20	20	12.5	22.5	45	10	20	7.000	4	1	229.00
3-I-40	40	12.5	42.5	45	10	40	14.00	4	1	259.00
<i>Spectrosil® Far UV Quartz windows, Useable range: 170 to 2700 nm</i>										
9F-Q-10	10	12.5	12.5	45	4	10	1.400	4	1	\$ 229.00
<i>Semi-Micro, OpenTop</i>										
17F-Q-10	10	12.5	12.5	25	2	10	0.400	4	1	\$ 199.00
18F-Q-10	10	12.5	12.5	45	2	10	0.700	4	1	265.00
<i>Micro, Open Top</i>										

Fluorometer Cells, Standard, Semi-Micro, Micro with stopper

Type 23 cells are identical to Standard Rectangular fluorometer cells as listed on page 26 except that instead of having an open rectangular hole at the top, a block is fused to the top of the cell with a ground hole to receive a PTFE stopper. This provides a more suitable seal for volatile liquids. A PTFE stopper is supplied with each cell. Two stoppers are supplied with cells which have a path length of 40mm or greater.

Smaller volume Types 29F and 28F are identical to Types 9F Semi-Micro and Type 18F Micro cell ranges except they have a stopper instead of a lid. A PTFE stopper is supplied with each cell.

Some applications require Anti-reflection coatings or Mirror coatings to be applied to two adjacent exterior walls to increase sensitivity and enhance the energy received by the detector.

To add the coatings to a cell, use the suffix /AR for Anti reflection and /MC for Mirror coating (e.g. 23-Q-10/AR/MC would be for both coatings, each on two adjacent faces). For prices see page 39.

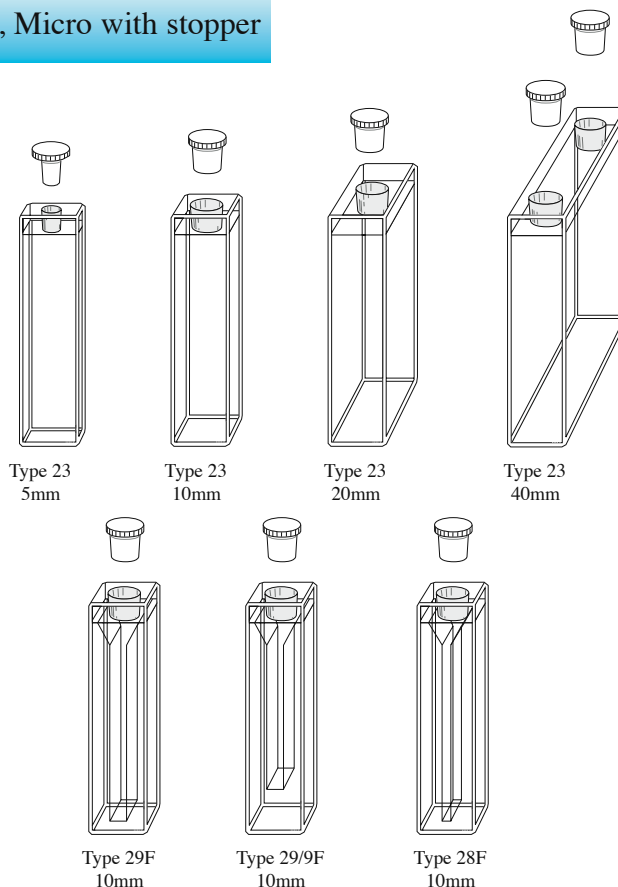

Catalog Number	Path Length mm	Exterior, mm			Interior, mm		Nominal Vol. ml	Polished Windows	Base	Price per cell
		Width	Length	Height	Width	Length				
<i>Optical Glass windows, Useable range: 334 to 2500 nm</i>										
23-G-5	5	12.5	7.5	48	10	5	1.700	4	1	\$ 95.00
23-G-10	10	12.5	12.5	48	10	10	3.500	4	1	89.00
23-G-20	20	12.5	22.5	48	10	20	7.000	4	1	135.00
23-G-40	40	12.5	42.5	48	10	40	14.00	4	1	165.00
<i>Special Optical Glass windows, Useable range: 320 to 2500 nm</i>										
23-SOG-10	10	12.5	12.5	48	10	10	3.500	4	1	\$ 129.00
<i>Spectrosil® Far UV Quartz windows, Useable range: 170 to 2700 nm</i>										
23-Q-5	5	12.5	7.5	48	10	5	1.700	4	1	\$ 199.00
23-Q-10	10	12.5	12.5	48	10	10	3.500	4	1	165.00
23-Q-20	20	12.5	22.5	48	10	20	7.000	4	1	229.00
23-Q-40	40	12.5	42.5	48	10	40	14.00	4	1	259.00
<i>Infrasil® or equivalent Near Infrared Quartz windows, Useable range: 220 to 3800 nm</i>										
23-I-5	5	12.5	7.5	48	10	5	1.700	4	1	\$ 229.00
23-I-10	10	12.5	12.5	48	10	10	3.500	4	1	215.00
23-I-20	20	12.5	22.5	48	10	20	7.000	4	1	289.00
23-I-40	40	12.5	42.5	48	10	40	14.00	4	1	329.00
<i>Spectrosil® Far UV Quartz windows, Useable range: 170 to 2700 nm</i>										
29F-Q-10	10	12.5	12.5	48	4	10	1.400	4	1	\$ 265.00
29/9F-Q-10	10	12.5	12.5	48	4	10	1.160	4	1	315.00
28F-Q-10	10	12.5	12.5	48	2	10	0.700	4	1	\$ 295.00

Semi-Micro, Stoppr

Micro, Stopper

Fluorometer Micro Square Cells, Adapters

This range of Micro Fluorometer cells has been specifically designed by Starna for use with the FCA range of adapters listed below. The adapter locates the square cross section cell accurately in the center of the instrument cell compartment. Therefore, for a given path length, the cell is optimized for minimum volume and maximum sensitivity. All four windows and the base of the cells are polished and are available with either an open top or with a PTFE stopper supplied with the type 23- cells.

The FCA adapters have exterior dimensions of a standard fluorometer cell (12.5mm x 12.5mm) and interior dimensions to accommodate the square micro fluorometer cells listed. Apertures are machined into the adapter wall to allow for transmission of the excitation and emission energy at either 8.5 or 15mm 'Z' dimension. The aluminum adapters are black anodized to eliminate stray light. The correct adapter for a particular cell can be identified from the listing below.

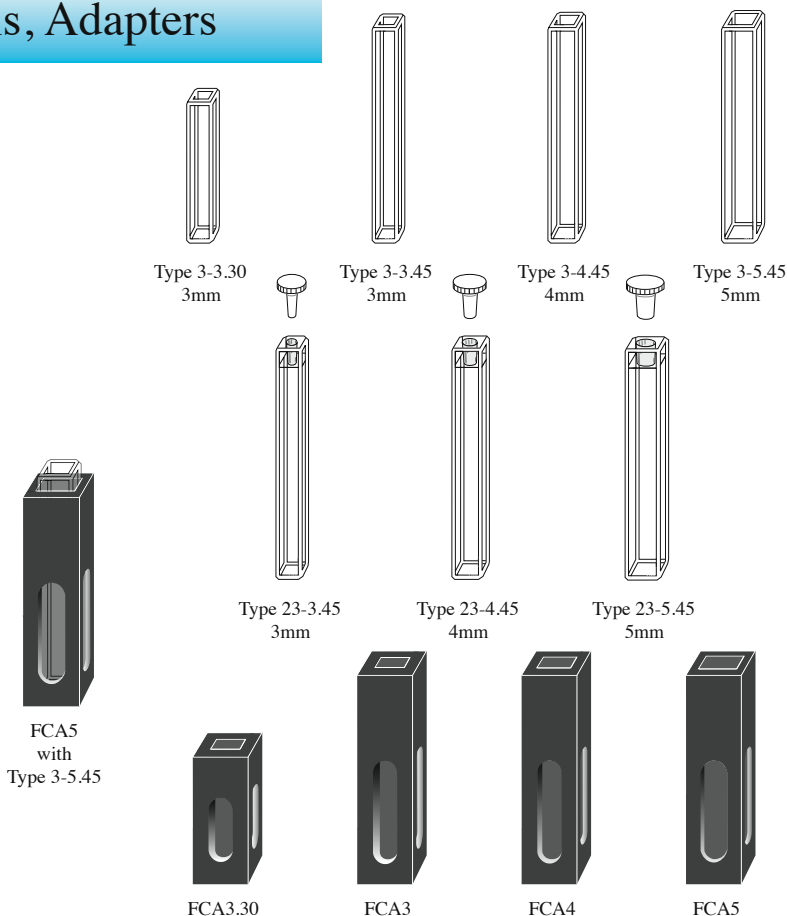

Adapter Aperture Dimensions

	Width mm	Height mm	Number of Openings
FCA3.30	2.5	11	3
FCA3	2.5	21	3
FCA4	3.5	21	3
FCA5	4.5	21	3

From the bottom of the adaptor to the bottom of the opening is 5.5 mm for all adaptors.

Catalog Number	Path Length mm	Exterior, mm			Interior, mm		Adapter	Nominal Vol. ml	Polished Windows	Price per cell
		Width	Length	Height	Width	Length				
<i>Special Optical Glass windows, Useable range: 320 to 2500 nm</i>										
3-3.30-SOG-3	3	5.5	5.5	30	3	3	FCA3.30	0.225	5	<i>Open Top</i> \$ 95.00
3-3.45-SOG-3	3	5.5	5.5	45	3	3	FCA3	0.315	5	95.00
3-4.45-SOG-4	4	6.5	6.5	45	4	4	FCA4	0.560	5	95.00
3-5.45-SOG-5	5	7.5	7.5	45	5	5	FCA5	0.875	5	95.00
<i>Stopper</i>										
23-3.45-SOG-3	3	5.5	5.5	48	3	3	FCA3	0.315	5	\$ 115.00
23-4.45-SOG-4	4	6.5	6.5	48	4	4	FCA4	0.560	5	115.00
23-5.45-SOG-5	5	7.5	7.5	48	5	5	FCA5	0.875	5	115.00
<i>Spectrosil® Far UV Quartz windows, Useable range: 170 to 2700 nm</i>										
3-3.30-Q-3	3	5.5	5.5	30	3	3	FCA3.30	0.225	5	<i>Open Top</i> \$ 195.00
3-3.45-Q-3	3	5.5	5.5	45	3	3	FCA3	0.315	5	195.00
3-4.45-Q-4	4	6.5	6.5	45	4	4	FCA4	0.560	5	195.00
3-5.45-Q-5	5	7.5	7.5	45	5	5	FCA5	0.875	5	195.00
<i>Stopper</i>										
23-3.45-Q-3	3	5.5	5.5	48	3	3	FCA3	0.315	5	\$ 219.00
23-4.45-Q-4	4	6.5	6.5	48	4	4	FCA4	0.560	5	219.00
23-5.45-Q-5	5	7.5	7.5	48	5	5	FCA5	0.875	5	219.00

Adapters for the above series of Micro cells

Catalog Number	Description	Exterior, mm			Interior, mm		Fit cell types	Price per adapter
		Width	Length	Height	Width	Length		
FCA3.30	Adapter	12.5	12.5	30	5.55	5.55	3-3.30	\$ 115.00
FCA3	Adapter	12.5	12.5	45	5.55	5.55	3-3, 23-3	115.00
FCA4	Adapter	12.5	12.5	45	6.55	6.55	3-4, 23-4	115.00
FCA5	Adapter	12.5	12.5	45	7.55	7.55	3-5, 23-5	115.00

Fluorometer Sub-Micro

Sub-Micro cells, Type 16F, while retaining the exterior dimensions of a standard cell, are designed for the measurement of very small samples with volumes ranging from 10 μ l to 160 μ l. The fluorometer Sub-Micro cells have a third window at 90° to the incident light to allow emission energy to be measured. Special adapters are not required for this cell.

The entrance to the sample compartment is hemispherical, being designed without sharp corners to eliminate potential loss of sample by capillary action. *The amount of sample required to fill the sample chamber is reduced to an absolute minimum, typically fifteen to twenty per cent greater than the absolute sample chamber volume.* The sample is easily inserted into and retrieved from the cell by careful use of a pipette or syringe.

The sample compartment in the Sub-micro range of cells optimizes the alignment of the sample for maximum sensitivity in the fluorometer. The correct 'Z' dimension needs to be selected for this range, typically 8.5 or 15 mm. Open top cells are supplied with a tight sealing polypropylene cap, as well as a PTFE lid.

'Z' Dimensions for some fluorometers

Manufacturer:	'Z' Dimension:
Hitachi®	varies by instrument
Jasco®	18mm
Molecular Devices®	15mm
Ocean Optics®	15mm
Perkin-Elmer®	15mm
Pharmacia®	15mm
PTI (Photon Technology)®	15mm
Shimadzu®	15mm
SLM/Spectronics®	15mm
Spectra Max®	15mm
Spex®	15mm
StellarNet®	15mm
TSS®	15mm
Varian®	20mm

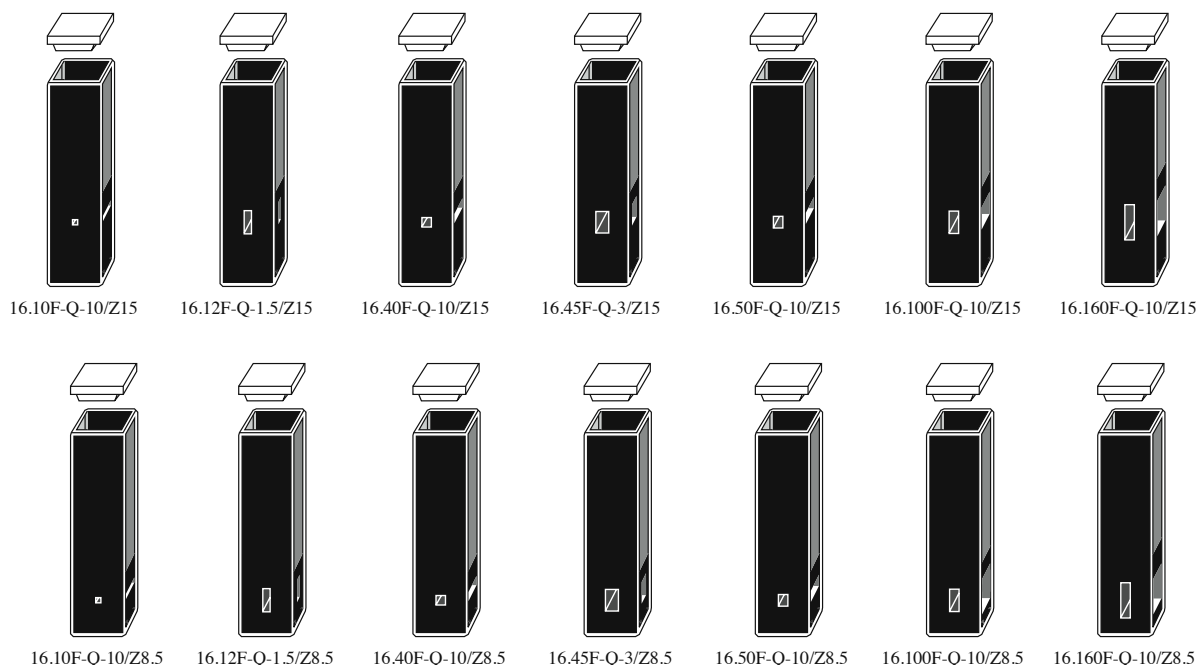

Catalog Number	Path Length Exterior, mm			Sample Chamber, mm			'Z' Dim mm	Nominal Vol. ml	Polished Windows	Price per cell	
	mm	Width	Length Height	Width	Length	Height					
<i>Spectrosil® Far UV Quartz windows, Useable range: 170 to 2700 nm</i>											
16.10F-Q-10/Z15	10	12.5	12.5	45	1	10	1	15	0.010	3	\$ 379.00
16.10F-Q-10/Z8.5	10	12.5	12.5	45	1	10	1	8.5	0.010	3	379.00
16.12F-Q-1.5/Z15	1.5	12.5	12.5	45	1.5	1.5	5	15	0.012	3	379.00
16.12F-Q-1.5/Z8.5	1.5	12.5	12.5	45	1.5	1.5	5	8.5	0.012	3	379.00
16.40F-Q-10/Z15	10	12.5	12.5	45	2	10	2	15	0.040	3	365.00
16.40F-Q-10/Z8.5	10	12.5	12.5	45	2	10	2	8.5	0.040	3	365.00
16.45F-Q-3/Z15	3	12.5	12.5	45	3	3	5	15	0.045	3	365.00
16.45F-Q-3/Z8.5	3	12.5	12.5	45	3	3	5	8.5	0.045	3	365.00
16.50F-Q-10/Z15	10	12.5	12.5	45	2	10	2.5	15	0.050	3	365.00
16.50F-Q-10/Z8.5	10	12.5	12.5	45	2	10	2.5	8.5	0.050	3	365.00
16.100F-Q-10/Z15	10	12.5	12.5	45	2	10	5	15	0.100	3	365.00
16.100F-Q-10/Z8.5	10	12.5	12.5	45	2	10	5	8.5	0.100	3	365.00
16.160F-Q-10/Z15	10	12.5	12.5	45	2	10	8	15	0.160	3	365.00
16.160F-Q-10/Z8.5	10	12.5	12.5	45	2	10	8	8.5	0.160	3	365.00

Fluorometer, Triangular, Dual Path Length

Triangular fluorometer cells Type 4, with open top or Type 24 with PTFE stopper, are useful for front surface fluorescence measurement. This technique is employed when the sample is too dense for the transmission of excitation or emission energy. Analysis is made by exciting the face of the sample at an angle of 45° to both the excitation source and the emission detector.

Dual path length cells Types 52 and 53 allow for both fluorescence and absorbance measurements to be made with small volumes with a choice of two path lengths, dependent on the orientation of the cell in the cell holder. All cells have a 10mm path length in one direction and a smaller path length at 90°. All four windows and the base are clear. Type 53 is supplied with a PTFE stopper.

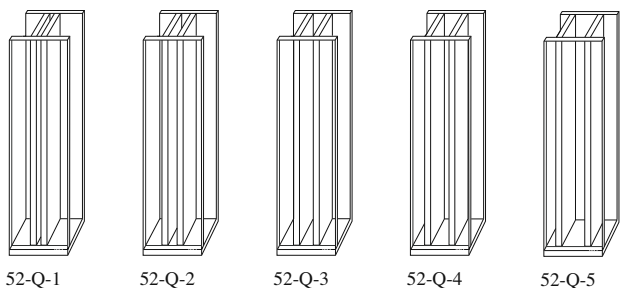

52-Q-1 52-Q-2 52-Q-3 52-Q-4 52-Q-5

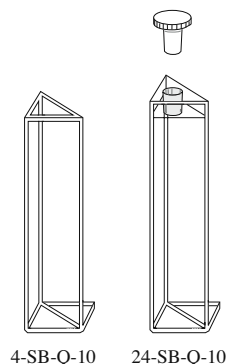

4-SB-Q-10 24-SB-Q-10

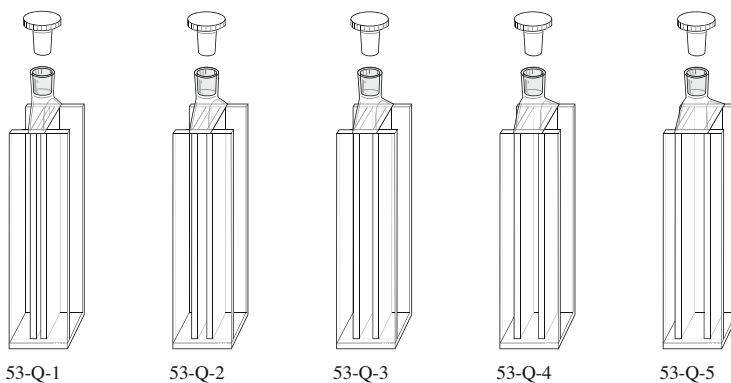

53-Q-1 53-Q-2 53-Q-3 53-Q-4 53-Q-5

Catalog Number	Path Length mm	Exterior, mm			Interior, mm		Nominal Vol. ml	Polished Windows	Price per cell
		Width	Length	Height	Width	Length			

Spectrosil® Far UV Quartz windows, Useable range: 170 to 2700 nm

4-SB-Q-10	Surface	12.5	12.5	45	10	10	1.700	3	\$ 215.00
24-SB-Q-10	Surface	12.5	12.5	48	10	10	1.700	3	\$ 275.00

Triangular, Open Top

Triangular, Stopper

Catalog Number	Path Length mm	Exterior, mm			Interior, mm		Nominal Vol. ml	Polished Windows	Price per cell
		Width	Length	Height	Width	Length			

Spectrosil® Far UV Quartz windows, Useable range: 170 to 2700 nm

52-Q-1	1 and 10	12.5	12.5	45	1	10	0.400	5	\$ 199.00
52-Q-2	2 and 10	12.5	12.5	45	2	10	0.800	5	199.00
52-Q-3	3 and 10	12.5	12.5	45	3	10	1.200	5	199.00
52-Q-4	4 and 10	12.5	12.5	45	4	10	1.600	5	199.00
52-Q-5	5 and 10	12.5	12.5	45	5	10	2.000	5	199.00
53-Q-1	1 and 10	12.5	12.5	48	1	10	0.400	5	\$ 229.00
53-Q-2	2 and 10	12.5	12.5	48	2	10	0.800	5	229.00
53-Q-3	3 and 10	12.5	12.5	48	3	10	1.200	5	229.00
53-Q-4	4 and 10	12.5	12.5	48	4	10	1.600	5	229.00
53-Q-5	5 and 10	12.5	12.5	48	5	10	2.000	5	229.00

Dual Path, Open Top

Dual Path, with Stopper

Fluorometer, Tandem or Divided Rectangular

Types 55, 56, 57 and 58 are all cells with two chambers which can be used either in parallel or series and with the exception of Type 55-1, have all walls polished. Types 57 and 58 have the facility for the intentional mixing of two liquids within the cell itself. PTFE stoppers supplied for type 56 and type 58 as pictured.

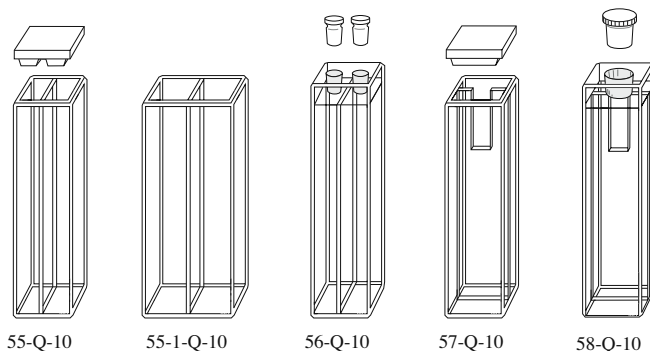

Catalog Number	Path Length mm	Exterior, mm			Interior, mm		Nominal Vol. ml	Polished Windows	Price per cell
		Width	Length	Height	Width	Length			
<i>Spectrosil® Far UV Quartz windows, Useable range: 170 to 2700 nm</i>							<i>Tandem or Divided Rectangular, Open top</i>		
55-Q-10	2 x 10	12.5	12.5	45	10	2 x 4.375	2 x 1.500	6	\$ 195.00
55-1-Q-10	2 x 10	12.5	23.75	45	10	2 x 10	2 x 3.500	3	239.00
							<i>Tandem or Divided Rectangular, with Stoppers</i>		
56-Q-10	2 x 10	12.5	12.5	48	10	2 x 4.375	2 x 1.500	6	\$ 295.00
							<i>Mixing, Tandem or Divided Rectangular, Open top</i>		
57-Q-10	2 x 10	12.5	12.5	45	10	2 x 4.375	2 x 1.000	6	\$ 245.00
							<i>Mixing, Tandem or Divided Rectangular, with Stoppers</i>		
58-Q-10	2 x 10	12.5	12.5	48	10	2 x 4.375	2 x 1.000	6	\$ 289.00

Fluorometer Screw Cap Cells, Closed and Septum

These fluorometer cells with the suffix **GL14** are able to be used under anaerobic conditions. The cells with the **GL14** suffix have a standard GL14 threaded top and cap which can be either a septum cap, GL14-S, or a plain closed cap, GL14-C.

GL14 Caps, Closed & Septum

Screw caps to fit GL14 threaded cells. Available as either closed cap or septum seal cap.

Cat. No	Description	Price, each
GL14-C	Closed cap	\$ 4.25
GL14-S	Septum seal cap	4.25
GL14/SI	Septum Insert	1.50

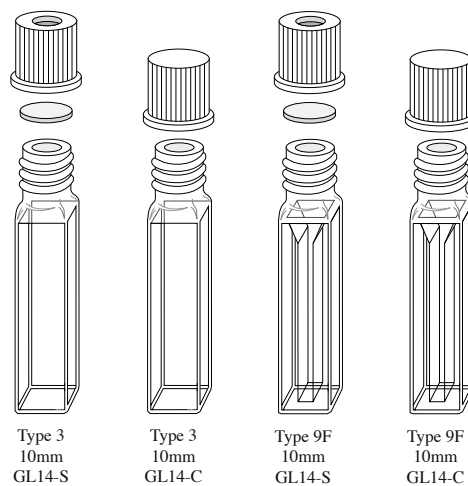

Catalog Number	Description	Path Length mm	Exterior, mm			Interior, mm		Nominal Vol. ml	Polished Windows	Base	Price each
			Width	Length	Height	Width	Length				
<i>Special Optical Glass windows, Useable range: 334 to 2500 nm</i>											
3-SOG-10-GL14-C	Closed Cap, Fluorometer	10	12.5	12.5	68	10	10	3.500	4	1	\$ 175.00
9F-SOG-10-GL14-C	Closed Cap, Semi-Micro,F	10	12.5	12.5	68	4	10	1.400	4	1	225.00
<i>Spectrosil® Far UV Quartz windows, Useable range: 170 to 2700 nm</i>											
3-Q-10-GL14-C	Closed Cap, Fluorometer	10	12.5	12.5	68	10	10	3.500	4	1	\$ 235.00
9F-Q-10-GL14-C	Closed Cap, Semi-Micro,F	10	12.5	12.5	68	4	10	1.400	4	1	319.00
<i>Special Optical Glass windows, Useable range: 334 to 2500 nm</i>											
3-SOG-10-GL14-S	Septum Cap, Fluorometer	10	12.5	12.5	68	10	10	3.500	4	1	\$ 175.00
9F-SOG-10-GL14-S	Septum Cap, Semi-Micro,F	10	12.5	12.5	68	4	10	1.400	4	1	225.00
<i>Spectrosil® Far UV Quartz windows, Useable range: 170 to 2700 nm</i>											
3-Q-10-GL14-S	Septum Cap, Fluorometer	10	12.5	12.5	68	10	10	3.500	4	1	\$ 235.00
9F-Q-10-GL14-S	Septum Cap, Semi-Micro,F	10	12.5	12.5	68	4	10	1.400	4	1	319.00

Fluorometer Flow Through

Type 583-F range of fluorometer flow cells is designed to fit most standard fluorometers. The inlet/outlet tubes are connected with a threaded M6 connector with PTFE tubing attached. A pair of M6 connectors is supplied with the type 583 cell. The cells have three clear windows. The excitation beam passes through the cell, which also allows the cell to be used for absorption spectroscopy as well. The emission window is at 90 degrees to the excitation windows.

The cells are available in several configurations offering a range of sample volumes. The 'Z' dimension is the distance from the bottom of the cell holder to the center of the excitation beam. It is important to match the cell 'Z' dimension with that of your instrument.

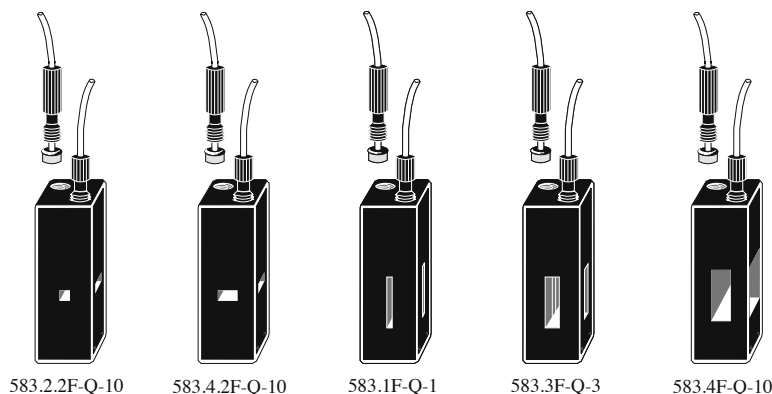

583.2.2F-Q-10 583.4.2F-Q-10 583.1F-Q-1 583.3F-Q-3 583.4F-Q-10

'Z' Dimensions for some fluorometers

Manufacturer:	'Z' Dimension:
Hitachi®	varies by instrument
Jasco®	18mm
Molecular Devices®	15mm
Ocean Optics®	15mm
Perkin-Elmer®	15mm
Pharmacia®	15mm
PTI (Photon Technology)®	15mm
Shimadzu®	15mm
SLM/Spectronics®	15mm
Spectra Max®	15mm
Spex®	15mm
StellarNet®	15mm
TSS®	15mm
Varian®	20mm

Flow cell Tubulation dimensions:

Type	OD	ID	Length
Non-Threaded:	3.5mm	2.2mm	10mm
M6	1.6mm	1mm	400mm

Extra M6 tubing sets may be ordered.

Each set has one inlet and one outlet tube each with an M6 connector. The tubing supplied is approximately 400 mm long.



Catalog#	Description	Price/set
M6-Set	M6 Inlet/Outlet tubes	\$ 69.00

Catalog Number	Path Length mm	Exterior, mm			Sample Chamber, mm			'Z' Dim mm	Nominal Vol ml	Polished Windows	Price per cell
		Width	Length	Height	Width	Length	Height				
<i>Spectrosil® Far UV Quartz windows, Useable range: 170 to 2700 nm</i>											
583.2.2F-Q-10/Z15	10	12.5	12.5	35	2	10	2	15	0.040	3	\$ 645.00
583.2.2F-Q-10/Z20	10	12.5	12.5	35	2	10	2	20	0.040	3	645.00
583.4.2F-Q-10/Z15	10	12.5	12.5	35	4	10	2	15	0.080	3	679.00
583.4.2F-Q-10/Z20	10	12.5	12.5	35	4	10	2	20	0.080	3	679.00
583.1F-Q-1/Z15	1	12.5	12.5	35	1	1	11	15	0.011	3	679.00
583.3F-Q-3/Z15	3	12.5	12.5	35	3	3	11	15	0.100	3	689.00
583.4F-Q-10/Z15	10	12.5	12.5	35	4	10	11	15	0.440	3	719.00

Fluorometer Flow Through

Fluorometer cells Type 46F and 47F (Semi-Micro) are for in-line continuous flow type applications, usually measuring at one wavelength. Samples normally flow from the bottom to the top.

Types 71F and 72F (Semi-Micro) fluorescent cells have long windows and will fit normal cell holders. They can be used with instruments of any 'Z' dimension and are particularly suitable for any application where sample volume is not critical.

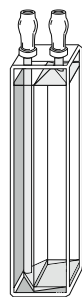

71F-Q-10

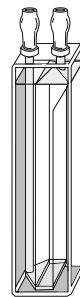

72F-Q-10

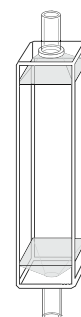

46F-Q-10

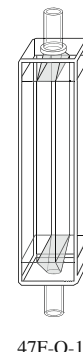

47F-Q-10

Catalog Number	Path Length mm	Exterior, mm			Sample Chamber, mm			'Z' Dim mm	Nominal Vol ml	Polished Windows	Price per cell
		Width	Length	Height	Width	Length	Height				
<i>Spectrosil® Far UV Quartz windows, Useable range: 170 to 2700 nm</i>											
46F-Q-10	10	12.5	12.5	45	10	10	40	all	4.000	4	\$ 505.00
47F-Q-10	10	12.5	12.5	45	4	10	40	all	1.600	4	\$ 589.00
71F-Q-10	10	12.5	12.5	48	7	10	40	all	3.000	3	\$ 445.00
72F-Q-10	10	12.5	12.5	48	4	10	40	all	1.800	3	\$ 459.00

Standard in-Line

Semi-Micro in-Line

Rectangular long window

Rectangular long window Semi-Micro

Fluorescence Reference Set

Molecular fluorescence spectroscopy is a sensitive and often selective technique. Unlike absorption spectrophotometry, it is not an absolute technique: instruments therefore require calibration before every series of measurements. This may be achieved using a stable reference material, which should absorb and emit at similar wavelengths to the samples of interest. Use of the general purpose fluorescent reference material set type 6BF enables the day to day stability of fluorescence instruments to be verified.

The 6BF reference materials are not standards with absolute values, but a set of six relatively stable fluorescent materials in a polymethylmethacrylate matrix with which the stability of the instrument can be monitored. Four blocks exhibit broad band spectra which cover the normally used UV and visible region of the spectrum. Two blocks contain materials suitable for illustrating the selectivity of the technique as well as checking instrument resolution and wavelength calibration.

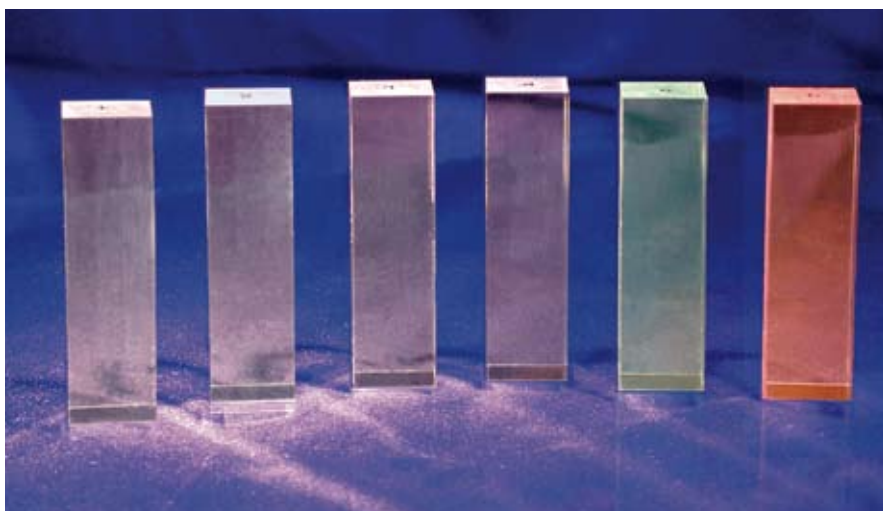

Acrylic polymer references for Fluorescence

Stability: no degradation, no evaporation
Safety: no chemicals to mix
Robust: unbreakable, easy to store and use
 For more information call for our 6BF technical reference

Catalog Number
6BF

Description
Fluorescence Reference Set, 6 polymer blocks

Price per Set
\$ 845.00

Dye Laser Cells

Dye laser cells must be made extremely accurately with a surface flatness which extends to the edge of the cell. Many of the fluorometer type of cells illustrated in this catalog may be used for laser applications. However, to ensure their optical flatness, fluorometer cells must be polished to more exacting tolerances and given the prefix **DLC**. There are other cells specifically designed listed below. The DLC-3-Q-10 is supplied with a PTFE lid while the other dye laser cells shown in the top row are supplied with a PTFE stopper. The DLC300-Q-20 and DLC300-Q-40 are supplied without a lid.

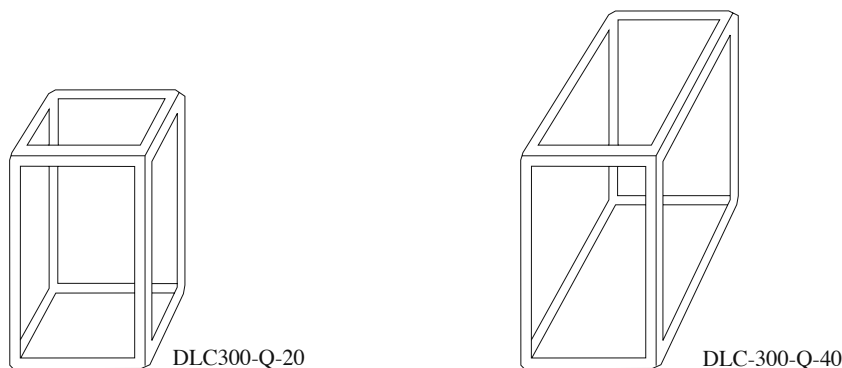
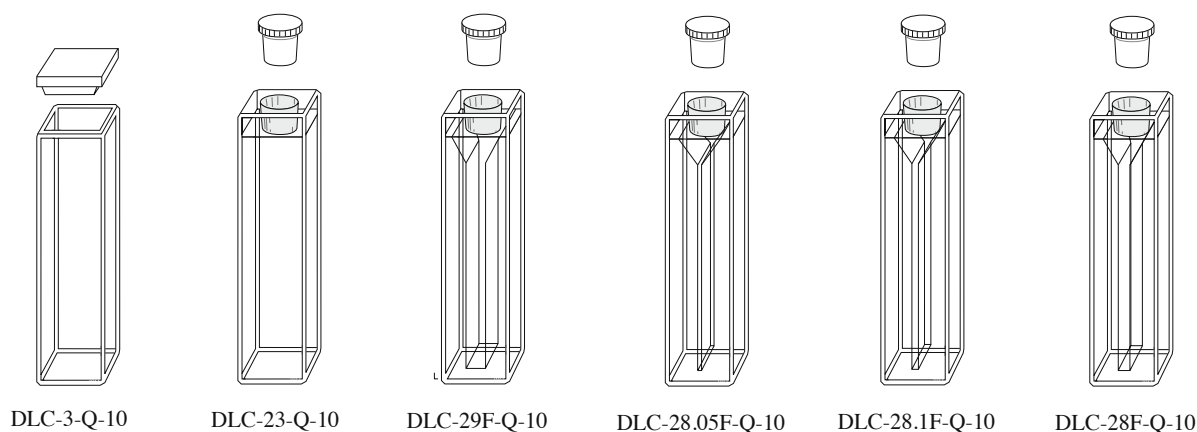

Catalog Number	Path Length mm	Exterior, mm			Interior, mm		Nominal Vol. ml	Polished		Price per cell
		Width	Length	Height	Width	Length		Windows	Base	
<i>Spectrosil® Far UV Quartz windows, Useable range: 170 to 2700 nm</i>										
DLC-3-Q-10	10	12.5	12.5	45	10	10	3.500	4	1	\$ 265.00
DLC-23-Q-10	10	12.5	12.5	48	10	10	3.500	4	1	309.00
DLC-29F-Q-10	10	12.5	12.5	48	4	10	1.400	4	1	365.00
DLC-28.05F-Q-10	10	12.5	12.5	48	0.5	10	0.175	4	1	415.00
DLC-28.1F-Q-10	10	12.5	12.5	48	1	10	0.350	4	1	439.00
DLC-28F-Q-10	10	12.5	12.5	48	2	10	0.700	4	1	405.00
DLC-300-Q-20	20	26	26	40	20	20	12.000	4	no	\$ 665.00
DLC-300-Q-40	40	26	46	40	20	40	24.000	4	no	769.00

Cells with Quartz to Pyrex Graded Seal

Quartz to Pyrex graded seals can be fused to most rectangular quartz cells, allowing them to be joined to other borosilicate apparatus. The price indicated is for the graded seal, the cost of fusing to a cell plus the cost of the chosen cell. The dimensions of the normal graded seals used are OD 10 mm, ID 8 mm, Length 70mm.

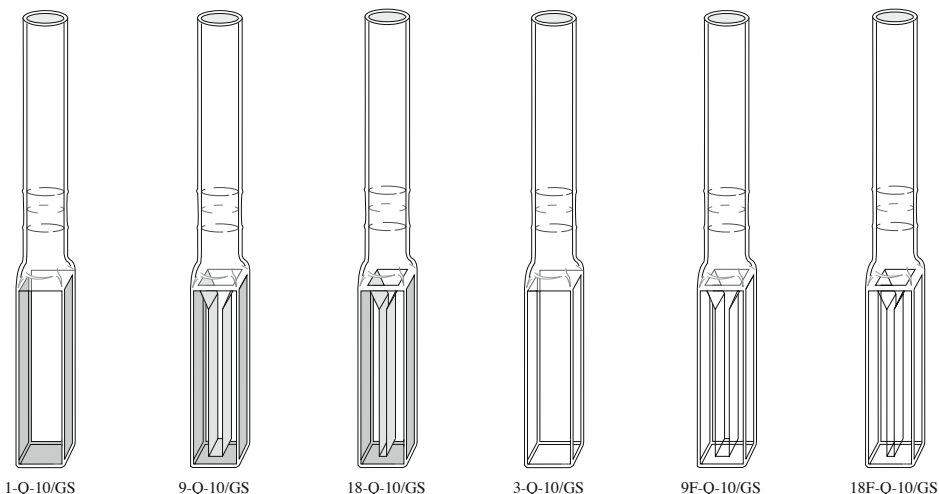

Catalog Number	Path Length mm	Exterior, mm			Interior, mm		Nominal Vol. ml	Polished Windows	Price per cell
		Width	Length	Height	Width	Length			
<i>Spectrosil® Far UV Quartz windows, Useable range: 170 to 2700 nm</i>									
1-Q-10/GS	10	12.5	12.5	115	10	10	3.500	2	\$ 219.00
9-Q-10/GS	10	12.5	12.5	115	4	10	1.400	2	259.00
18-Q-10/GS	10	12.5	12.5	115	2	10	0.700	2	265.00
3-Q-10/GS	10	12.5	12.5	115	10	10	3.500	5	269.00
9F-Q-10/GS	10	12.5	12.5	115	4	10	1.400	5	369.00
18F-Q-10/GS	10	12.5	12.5	115	2	10	0.700	5	405.00

Cells with Straight Bore Tube

Straight bore tubes in a range of sizes can be attached to most cells. Quartz tubes can be fused to quartz cells but for Glass materials, the tube and the cell need to be fabricated from borosilicate glass. Prices quoted are for the cost of the tube and fusing it to the cell plus the original cell cost. The dimensions of the standard tubes supplied are OD 10 mm, ID 8 mm, Length 70mm.

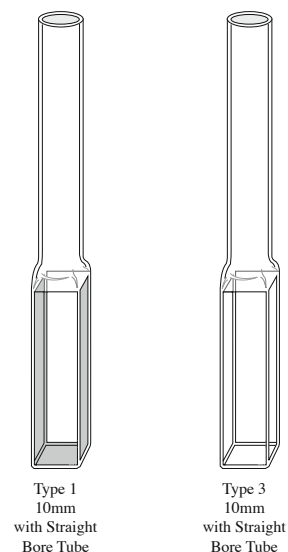

Catalog Number	Path Length mm	Exterior, mm			Interior, mm		Nominal Vol. ml	Polished Windows	Price per cell
		Width	Length	Height	Width	Length			
<i>Special Optical Glass windows, Useable range: 320 to 2500 nm</i>									
1-SOG-10/SBT	10	12.5	12.5	115	10	10	3.500	2	\$ 175.00
<i>Spectrosil® Far UV Quartz windows, Useable range: 170 to 2700 nm</i>									
1-Q-10/SBT	10	12.5	12.5	115	10	10	3.500	2	\$ 209.00
3-Q-10/SBT	10	12.5	12.5	115	10	10	3.500	5	259.00

Colorimeter Cells

Colorimeter cells are fully fused glass cells for use with colorimeters. Each cell has two polished windows and an open top with no cover.

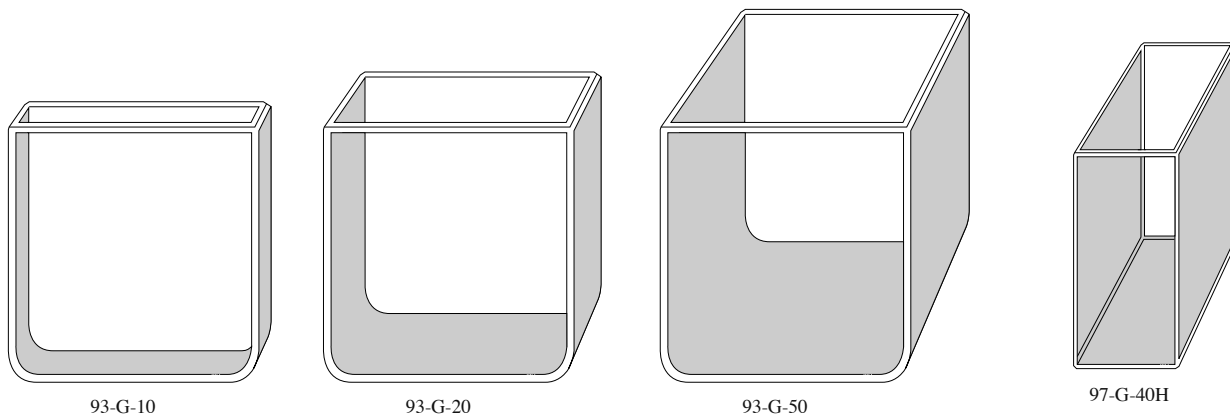

93-G-10

93-G-20

93-G-50

97-G-40H

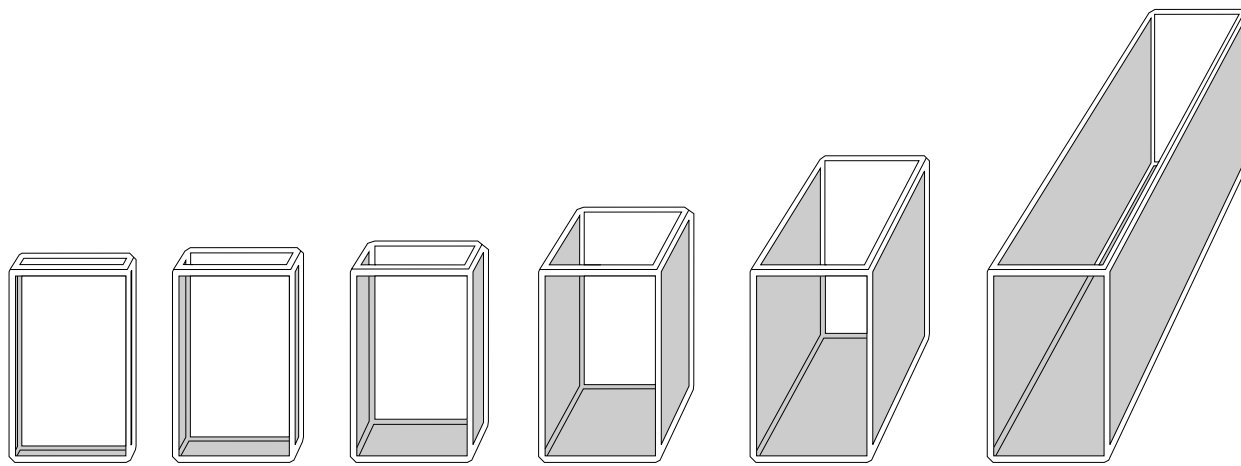

96-G-2.5

96-G-5

96-G-10

96-G-20

96-G-40

96-G-100

Catalog Number	Path Length mm	Exterior, mm			Interior, mm		Nominal Vol. ml	Polished Windows	Price per cell
		Width	Length	Height	Width	Length			

For use with: Hunter Colorimeter, ACS, Data Color and others

93-G-10	10	55	14	56	51	10	25	2	\$ 125.00
93-G-20	20	55	24	56	51	20	50	2	155.00
93-G-50	50	55	54	56	51	50	125	2	245.00

For use with: CP method and general colorimetric work

97-G-40H	40	20	44	45	16	40	25	2	\$ 72.00
----------	----	----	----	----	----	----	----	---	----------

For use with: Absorptimeters

96-G-2.5	2.5	28	8.5	40	24	2.5	1.8	2	\$ 42.00
96-G-5	5	28	11	40	24	5	3.6	2	42.00
96-G-10	10	28	16	40	24	10	7.2	2	42.00
96-G-20	20	28	26	40	24	20	14	2	55.00
96-G-40	40	28	46	40	24	40	28	2	75.00
96-G-100	100	28	106	40	24	100	70	2	115.00

Cells for use with Magnetic Stirrers

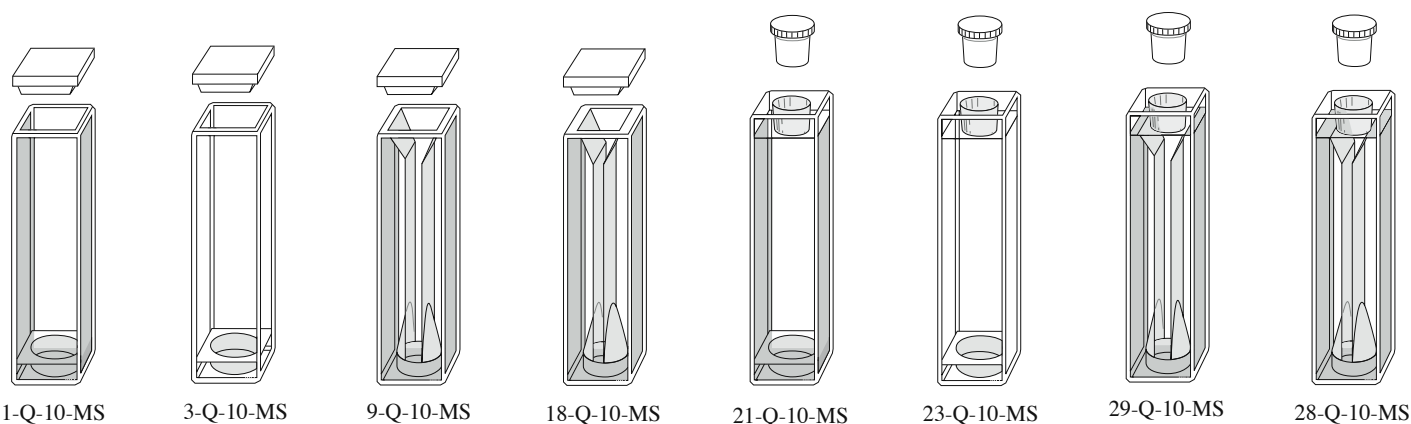

This range of spectrophotometer cells is designed specifically for use with magnetic stir bar type stirrers. The circular recess in the bottom both contains the stir bar and increases the stirring efficiency. Cells are supplied with a PTFE lid or stopper as pictured.

Catalog Number	Description	Windows Clear	Material	Nominal Volume	Price per cell
1-Q-10-MS	Stirring Cell, Standard Rectangular	2	Far UV Quartz	3.5	\$ 175.00
3-Q-10-MS	Stirring Cell, Fluorometer Rectangular	4	Far UV Quartz	3.5	249.00
9-Q-10-MS	Stirring Cell, Semi-Micro Rectangular	2	Far UV Quartz	1.8	219.00
18-Q-10-MS	Stirring Cell, Micro Rectangular	2	Far UV Quartz	0.9	239.00
21-Q-10-MS	Stirring Cell, Standard with Stopper	2	Far UV Quartz	3.5	225.00
23-Q-10-MS	Stirring Cell, Fluorometer with Stopper	4	Far UV Quartz	3.5	305.00
29-Q-10-MS	Stirring Cell, Semi-Micro with Stopper	2	Far UV Quartz	1.8	259.00
28-Q-10-MS	Stirring Cell, Micro with Stopper	2	Far UV Quartz	0.9	275.00
MSB-6X1.5	Magnetic Stirring Bars for above cells, 6mm x 1.5mm, 10/Pack				\$ 42.00/pack
MSB-6X3	Magnetic Stirring Bars for above cells, 6mm x 3mm, 10/Pack				\$ 42.00/pack

Flow Cells, In-Line or Microscope Analysis

The type 45 flow cells provide a large surface to view materials as they flow through the chamber. The thin dimension (3 to 4.5mm external thickness) makes this cell ideal for use with most microscopes.

The inlet/outlet tube dimensions are 25mm long:
Up to 2mm pathlength: 2mm ID, 4mm OD
5mm pathlength: 5mm ID, 7mm OD

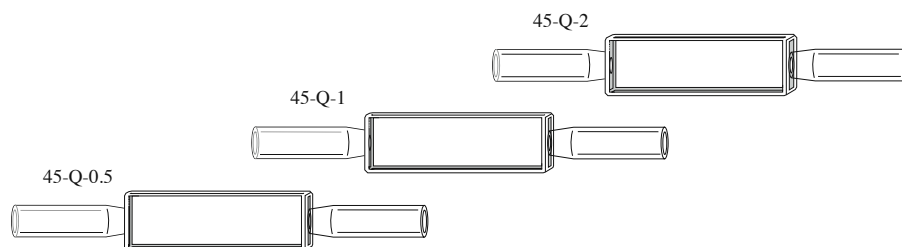

Catalog Number	Path Length mm	Exterior, mm			Interior, mm		Nominal Vol. ml	Polished Windows	Price per cell
		Width	Length	Height	Width	Length			
<i>Spectrosil® Far UV Quartz windows, Useable range: 170 to 2700 nm</i>									
45-Q-0.5	0.5	12.5	3.0	40 + tubes	10	0.5	0.225	2	\$ 355.00
45-Q-1	1	12.5	3.5	40 + tubes	10	1	0.450	2	289.00
45-Q-2	2	12.5	4.5	40 + tubes	10	2	0.900	2	269.00

Constant Temperature Cells

Constant temperature cell Types 62, 63 and 65 are designed with a separate chamber surrounding the sample compartment through which a temperature controlling fluid can be circulated to keep the sample at a specific temperature. Type 62 cells have connection tubes exiting from the top, Type 63 on the front face and Type 65 on the upper portion of the cell. The light beam of the spectrophotometer is not intended to pass through the water jacket. PTFE stoppers are supplied as pictured.

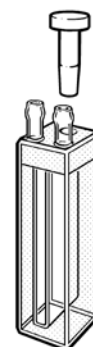

Type 62

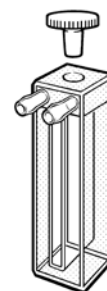

Type 63



Type 65
10mm



Type 65
20mm



Type 65
50mm

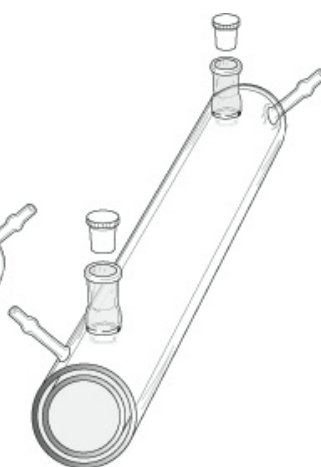

Type 65
100mm

Catalog Number	Path Length mm	Exterior, mm			Sample Chamber, mm			Overall Height	Nominal Vol ml	Polished Windows	Price per cell
		Width	Length	Height	Width	Length	Height				
<i>Spectrosil® Far UV Quartz windows, Useable range: 170 to 2700 nm</i>											
62-Q-10	10	12.5	12.5	48	4	10	40	60	1.520	2	\$ 379.00
<i>Rectangular, Vertical Flow Tubes</i>											
63-Q-10	10	12.5	12.5	48	4	10	40	60	1.520	2	\$ 379.00
<i>Rectangular, Horizontal Flow Tubes</i>											

Catalog Number	Path Length mm	Exterior, mm		Sample Chamber, mm		Overall Height	Nominal Vol ml	Polished Windows	Price per cell	
		Diameter	Length	Diameter	Length					
<i>Spectrosil® Far UV Quartz windows, Useable range: 170 to 2700 nm</i>										
65-Q-0.01	0.01	22	20	10	0.01	32	0.737	2	\$ 815.00	
65-Q-0.1	0.1	22	20	10	0.1	32	0.747	2	725.00	
65-Q-1	1	22	20	10	1	32	0.849	2	545.00	
65-Q-2	2	22	20	10	2	32	0.962	2	535.00	
65-Q-5	5	22	20	10	5	32	1.300	2	499.00	
65-Q-10	10	22	20	13	10	32	0.825	2	289.00	
65-Q-20	20	22	20	13	20	32	1.650	2	325.00	
65-Q-50	50	22	50	13	50	32	4.125	2	395.00	
65-Q-100	100	22	100	13	100	32	8.250	2	499.00	
<i>Cylindrical</i>										

Cell Cleaning Suggestions

Why Clean Cells?

Clean cells are the foundation of any spectrophotometric or fluorometric analysis. The residue from previous analysis will cause inaccuracies, low sensitivity and lack of precision. More important, it will waste your time! Also inspect the condition of the cells. If they are cracked, chipped or scratched it is important to replace the cells with new ones as your time is more valuable than the cost of new cells.

How to Clean Cells: It is important to determine the residual material in the cell that needs to be removed. The table below will give you some suggestions for cleaning:

Solvent	Material	Suggested Cleaning Methods
Aqueous	Protein, DNA, Biologics	Warm water with detergent, Dilute acid rinse, Copious water rinse
Aqueous	Salt solution	Warm water Acid rinse, copious water rinse
Aqueous	Basic solutions	Warm water with detergent, Dilute acid rinse, Copious water rinse
Organic	Oil based	Rinse with solvent, Warm water with detergent, Dilute acid rinse, Copious water rinse
Organic	Alcohol solutions	Rinse with solvent, Copious water rinse
Organic	Acidic solutions	Rinse with solvent, Copious water rinse
Organic	Basic solutions	Rinse with solvent, Dilute acid rinse, Copious water rinse

Fluorescence measurements - Clean cells in Nitric Acid (5M) use a copious water rinse immediately before use.

General Considerations:- Keeping cell clean while in use is the most important element of a long, useful Cell life. During the day, never let your cells dry out. If you keep them in a water or solvent bath between usage, the material that you are using will not have a chance to dry out and stick. Use only lens cleaning paper or fine cloth to wipe the optical surfaces, most paper products contain wood fibres which may scratch or damage the cell face or surface. At the end of the day, ensure all cells are well cleaned and store in a suitable container after drying.

Definitions

Dilute Acid	Dilute Hydrochloric acid (2M) or Nitric Acid (2M)
Acid	Hydrochloric (5M) acid or Nitric Acid (5M) (see note below)
Solvent rinse	Rinse with the solvent that solvated your sample in the first place!
Copious water rinse	Use a pure water like deionized, distilled or RO and rinse at least 10 times
Detergent	Use a neutral pH detergent if available but dilute acid wash and water rinse to remove detergent residues

Important Exceptions:

5M Nitric acid: Do not use this treatment on Anti-reflection or mirror coated cells

Ultrasonic Cleaners: We do not recommend the use of ultrasonic cleaning baths with cells. Each bath generates a different frequency and if your bath operates at the resonant frequency of a cell, the cell will break. We do not warranty our cells for cleaning in an ultrasonic cleaner.

Cell Accessories

Anti reflection & Mirror Coatings

Some fluorescent applications require either or both the excitation and emission energy to be enhanced by applying a metallic mirror coating to the outside of adjacent windows opposite to the source and the detector windows.

Similarly, Anti reflection coatings on the other windows reduce reflective losses. For information and a quote on either mirror coating or anti reflective coating please give us a call.

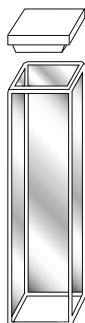

Cell Holder, long path length

Cell holders Type CH-1/50 and CH-1/100 are for rectangular cells up to 50 and 100mm path lengths respectively. The CH-34/100 will fit 50 or 100mm Type 34. All come complete with a 3" x 2" back plate to fit standard Infrared instrument holders.

Cat. No	Description	Price, each
CH-1/50	Rectangular to 50mm	\$ 255.00
CH-1/100	Rectangular to 100mm	315.00
CH-32/25	Cylindrical 10 to 25mm	79.00
CH-34/100	Cylindrical 50 to 100mm	89.00

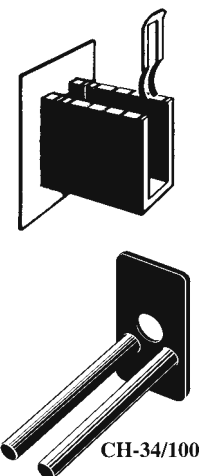

UV/Vis Reference Set, NIST Traceable, ISO 17025 Certified

The Importance of UV/Vis Verification

Each spectrophotometer has an expected performance that is listed in your instrument user's manual which was supplied with your instrument. It is essential that you verify that your instrument performs as the manufacturer specified so that you can assure that your measurements are accurate. The NIST traceable reference set, RM-06HLKI, can help you to test the three most important parameters of your spectrophotometer. These are absorbance scale, wavelength scale and stray light. The reference set is very easy to use. There is no chemical preparation. Each reference is a far UV quartz cell which has had the reference materials permanently heat sealed into the cells.

Certificate of Calibration and Traceability

Each set comes with a NIST traceable certificate of analysis. Our certification laboratory is inspected and accredited by UKAS under ISO/IEC 17025 and ISO Guide 34.

Potassium Dichromate

Used for: Verification of the UV absorbance scale
Useable range: 235nm to 350nm

The potassium dichromate reference is supplied as two cells, a blank and a 60mg/L cell. The 60mg/L cell is read against the blank at four wavelengths: 235, 257, 313, and 350nm. The certificate provided will give the expected absorbance values at those wavelengths.

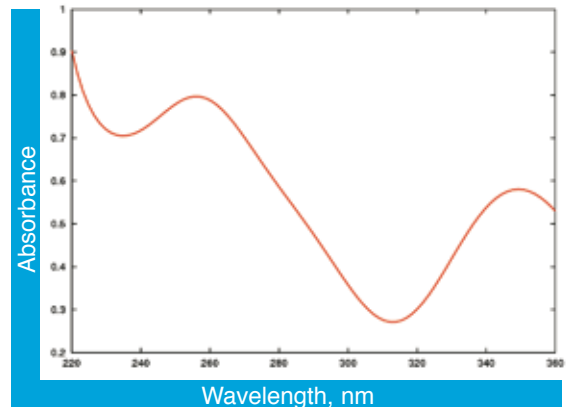

Holmium Perchlorate

Used for: Verification of the wavelength scale
Useable range: 240nm to 650nm

Holmium perchlorate has 14 defined (by NIST) absorbance peaks. You can relate the wavelengths at which your instrument finds these peaks to the wavelength scale of your instrument. Periodic use will assure that your wavelength scale is correct. Holmium has sharply defined peaks across both the UV and the visible spectra.

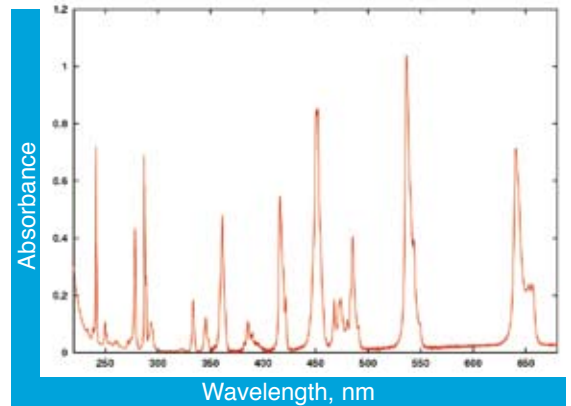

Potassium Iodide

Used for: Stray Light assessment
Useable range: 190 nm to 280nm

Stray light is an indication of transmitted light by your instrument when no light is being transmitted through the sample. Stray light can create problems with both sensitivity and accuracy if it exceeds the specification for your instrument. Potassium Iodide will allow you to easily test and assure that stray light is not out of specification.

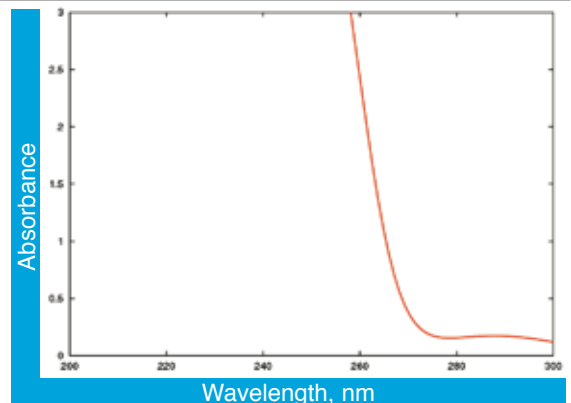

UV/Vis Reference Set, NIST Traceable, ISO 17025 Certified



The RM-06HLKI set contains:

Material	Concentration	Reference used to:
Potassium Dichromate	60mg/L in 0.001N perchloric acid	Verify the absorbance scale
Potassium Dichromate	0.001N perchloric acid	Blank for Potassium Dichromate
Holmium Perchlorate	4% in 10% perchloric acid	Verify the Wavelength Scale
Potassium Iodide	1% Aqueous	Verify Stray Light specification
Potassium Iodide	solvent only	Blank for Stray Light

All of the above references are made from high quality far UV quartz cells which have been filled and permanently fused closed. The caps of each reference are color coded for the reference type and have a label on the top of each cell indicating its contents. Each cell has a serial number engraved which is listed on the certificate of NIST Traceability supplied with the set. Recertification of the set is available. Call us for details.

Catalog Number	Description	Price each
RM-06HLKI	UV/Vis Reference Set, NIST Traceable, ISO 17025 Certified	\$ 1,890.00

Sets for Simplified Instrument Verifications

UV/Vis Reference Sets, NIST Traceable, ISO 17025 Certified

To make your verification task easier, we have assembled our reference materials into sets which allow you to meet specific verification requirements. In addition, you can save money by purchasing a group of references in a set instead of purchasing several references individually. We have sets which will allow you to meet the qualifications of the European Pharmacopoeia, the United States Pharmacopoeia and one set that will satisfy the requirements of both the EP and USP.

Certificate of Calibration and Traceability
Each set comes with a NIST traceable certificate of analysis. Our certification laboratory is inspected and accredited by UKAS under ISO/IEC 17025 and ISO Guide 34.



European Pharmacopoeia:

Catalog Number: **RM-0660HLKCTX**

NIST Traceable

Price per set: **\$ 2,840.00**

This set is used to meet European Pharmacopoeia requirements. This set contains:

Potassium Dichromate blank	Photometric Accuracy	235 nm to 350 nm
Potassium Dichromate 60 mg/L	Photometric Accuracy	235 nm to 350 nm
Potassium Dichromate 600 mg/L	Photometric Accuracy	430 nm
Holmium Perchloric	Wavelength Accuracy	240 nm to 650 nm
Stray Light blank	Stray Light	200 nm to 400 nm
Potassium Chloride, blank	Stray Light	200 nm
Toluene in Hexane	Resolution	267 nm to 268.7 nm

European Pharmacopoeia and USP:

Catalog Number: **RM-0660HLKCSITX**

NIST Traceable

Price per set: **\$ 3,290.00**

This set meets European Pharmacopoeia requirements as well as the requirements of the United States Pharmacopoeia. This set contains:

Potassium Dichromate blank	Photometric Accuracy	235 nm to 350 nm
Potassium Dichromate 60 mg/L	Photometric Accuracy	235 nm to 350 nm
Potassium Dichromate 600 mg/L	Photometric Accuracy	430 nm
Holmium Perchloric	Wavelength Accuracy	240 nm to 650 nm
Stray Light blank	Stray Light	200 nm to 400 nm
Potassium Chloride	Stray Light	200 nm
Sodium Iodide	Stray Light	220 nm
Toluene in Hexane	Resolution	267 nm to 268.7 nm

United States Pharmacopoeia set:

Catalog Number: **RM-06HLKI**

NIST Traceable

Price per set: \$ **1,890.00**

This set is primarily used in North America because of the similarity to NIST SRM's. The set contains:

Potassium Dichromate blank	Photometric Accuracy	235 nm to 350 nm
Potassium Dichromate 60 mg/L	Photometric Accuracy	235 nm to 350 nm
Holmium Perchloric	Wavelength Accuracy	240 nm to 650 nm
Stray Light blank	Stray Light	200 nm to 400 nm
Potassium Iodide	Stray Light	260 nm

United States Pharmacopoeia set with Didymium:

Catalog Number: **RM-06DLKI**

NIST Traceable

Price per set: \$ **1,890.00**

This set is used where wavelength verification is needed at higher visible wavelengths. The set contains:

Potassium Dichromate blank	Photometric Accuracy	235 nm to 350 nm
Potassium Dichromate 60 mg/L	Photometric Accuracy	235 nm to 350 nm
Didymium Perchloric	Wavelength Accuracy	290 nm to 870 nm
Stray Light blank	Stray Light	200 nm to 400 nm
Potassium Iodide	Stray Light	260 nm

United States Pharmacopoeia set with linearity:

Catalog Number: **RM-020610HLKI**

NIST Traceable

Price per set: \$ **2,490.00**

This set is used where absorbance linearity in the UV can be validated as well as the wavelength and stray light requirements of the USP. The set contains:

Potassium Dichromate blank	Photometric Accuracy	235 nm to 350 nm
Potassium Dichromate 20 mg/L	Photometric Accuracy	235 nm to 350 nm
Potassium Dichromate 60 mg/L	Photometric Accuracy	235 nm to 350 nm
Potassium Dichromate 100 mg/L	Photometric Accuracy	235 nm to 350 nm
Holmium Perchloric	Wavelength Accuracy	240 nm to 650 nm
Potassium Iodide, blank	Stray Light	260 nm

UV Absorbtion Scale Linearity:

Catalog Number: **RM-0204060810**

NIST Traceable

Price per set: \$ **1,990.00**

This set has five different concentrations of Potassium Dichromate and can be used to test both the photometric scale and linearity. The set contains:

Potassium Dichromate Blank		
Potassium Dichromate 20, 40, 60, 80, 100 mg/L	Photometric Accuracy	235 nm to 350 nm

Visible Absorbtion and Transmission Scale:

Catalog Number: **RM-1N2N3N**

NIST Traceable

Price per set: \$ **1,190.00**

This set has three neutral density filters and a blank. The filters are mounted in anodized aluminum holders which are the size of a standard cuvette. The set contains:

Neutral Density Blank		
Neutral Density Filters, 10%, 20% and 30%T	Photometric Accuracy	440.0 nm to 635.0 nm

Presorted Standard
US Postage Paid
San Luis Obispo, CA
Permit #7

Terms of Sale

Our terms of sale are Mastercard/VISA, American Express or net 30 days to recognized accounts. If you are unsure of your account status, please call us so that we can verify your account for you. The prices published in this catalog are current at the time of publication and are subject to change without notice.

Our terms of shipment are FOB Atascadero, CA USA.

Method of Shipment

We usually ship via United Parcel Service and have all levels of service available including Red (overnight). If required we can also ship via Federal Express. Foreign orders are usually shipped via Federal Express or UPS. All shipping charges are prepaid and added to the invoice.

In Stock

A great effort is made to keep most items in stock so that your order may be shipped on the same day that we receive it. However, at times we are out of stock and we will backorder any products that we could not ship to you immediately. Your backordered items will ship on the same day that they are received from our manufacturing facility.

Starna Cells, Inc

Mail orders:

Starna Cells, Inc
PO Box 1919
Atascadero, CA 93423

Phone Orders:

(800) 228-4482
or
(805) 466-8855

E-Mail Address:

sales@starnacells.com

FAX Orders:

(805) 461-1575

World Wide Web Site:

<http://www.starnacells.com>

Cell Matching

With common cells, such as the standard rectangular cell type 1-Q-10, the size of the matched set is virtually unlimited. The less commonly used cells can usually be matched in sets of 2 or 4 cells. All cells are priced as single cells but, when you order multiples of the same cell, we make every effort to match the cells as closely as possible.

Product Warranty

Our Starna® brand Spectrophotometer and Fluorometer cells are warranted to meet the specifications for transmission as listed in the specification table on page two of this catalog. In addition, the dimensions of each cell are warranted to be within the description of physical dimensions listed in this catalog. If the transmission or dimensions are not to your satisfaction, please call us within fifteen days of your receipt of the cells for warranty repair or replacement. We perform extensive quality control over our production and use only branded materials to assure you receive a cell that will perform to the maximum specification of your instrument. Any goods to be returned under warranty require a Return of Merchandise Authorization (RMA) number. The RMA can be obtained by calling our customer service department.

Technical Information

We have technical staff available to assist you with any information that you may need for the selection of a cell. If you are unsure of the material or physical configuration of a cell, please give us a call and we will be pleased to answer any questions that you may have. For advice on the cleaning of cells please see the cleaning guide on page 39 of this catalog.

Our hours of business are 8:30AM to 4:30PM, Pacific Time